

ADR-A SERIES

- ▶ Direct drive brushless motor
- ▶ Fully integrated with encoder and bearing
- ▶ Low cogging torque
- ▶ Precise homing through index pulse
- ▶ Low speed and high speed windings

ADR110-A75

ADR110-A75				
Performance Parameters	Symbol	Unit	Series	Parallel
Continuous Torque @100°C	T _{cn}	Nm	1.9	1.9
Peak Torque	T _{pk}	Nm	5.8	5.8
Torque Constant ±10%	K _t	Nm/Arms	0.65	0.32
Back EMF constant ±10%	K _e	Vpeak/rpm	0.055	0.028
Motor Constant @25°C	K _m	Nm/Sqrt(W)	0.30	0.30
Resistance (L-L) @25°C ±10%	R ₂₅	Ω	3.20	0.80
Inductance (L-L) ±20%	L	mH	17.15	4.29
Electrical time constant	τ _e	ms	5.36	5.36
Continuous Current @100°C	I _{cn}	Arms	3.0	6.0
Peak Current	I _{pk}	Arms	9.0	18.0
Continuous Power Dissipation @100°C	P _{cn}	W	55.7	55.7
Max. Coil Temperature	T _{max}	°C	100.0	100.0
Thermal Dissipation Constant	K _{thn}	W/°C	0.7	0.7
Max. Bus Voltage	U _{bus}	Vdc	600.0	600.0
Pole Number	p	-	16	16
Rec. Max Speed @230V AC	Ω _{max}	rpm	1700	2000
Mechanical Parameters				
Overall Mass	m _n	kg	3.20	3.20
Rotor Inertia	J _r	kg·m ²	3.086E-04	3.086E-04
Axial Runout	-	μm	15 (10,5)	15 (10,5)
Radial Runout	-	μm	15 (10,5)	15 (10,5)
Max Axial Load (Upright Mounting)	-	N	700	700
Max Axial Load (Inverted / Wall mounting)	-	N	150	150
Max Moment Load (Upright Mounting)	-	Nm	20	20
Max Moment Load (Inverted / Wall Mounting)	-	Nm	2.2	2.2
Encoder Parameters				
ABI Optical Incremental Encoder (SIN/COS)	-	lines / rev	3005	3005
ABI Optical Incremental Encoder Digital Resolution (80x)	-	counts / rev	240400	240400
ABI Optical Incremental Encoder Digital Resolution (160x)	-	counts / rev	480800	480800
ABI Optical Incremental Encoder Digital Resolution (400x)	-	counts / rev	1202000	1202000
Accuracy with Error Mapping	-	arc sec	+/-5.4	+/-5.4
Repeatability	-	arc sec	+/-2.7	+/-2.7
Other Information				
Insulation Class	Class B (130°C)			
Protection Grade	IP40			
Compliance with Global Standards	RoHS, CE, UL (option)			
Ambient Temperature	Operation	0°C to 40°C (non-freezing)		
	Storage	-15°C to 70°C (non-freezing)		
Ambient Humidity	Operation	10%RH to 80%RH (non-condensing)		
	Storage	10%RH to 90%RH (non-condensing)		
Recommended Ambience	Indoor (no direct sunlight); No corrosive gas, inflammable gas, oil mist or dust.			

- ① Measurement is taken at ambient temperature 25°C. Value depends on the thermal environment.
 - ② Resistance is measured by DC current with standard 3 m cable.
 - ③ Inductance is measured by current frequency of 1 kHz.
 - ④ The value is based on ABI optical SIN/COS encoder (4096x interpolation) under maximum bus voltage.
 - ⑤ The runout value in parenthesis is optional.
 - ⑥ Please refer to the illustration for different mountings.
 - ⑦ Based on ABI optical SIN/COS encoder (4096x interpolation) with standard runout.
- The contents of datasheet are subjected to change.

Torque-Speed Curve

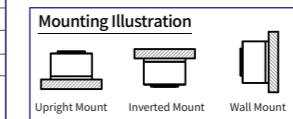
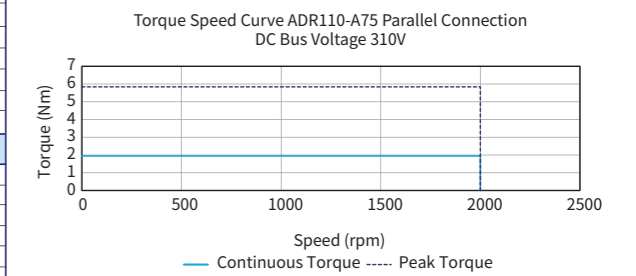
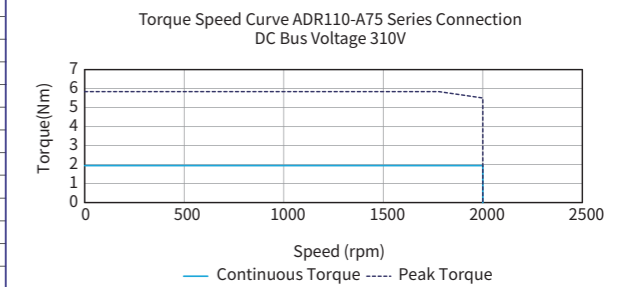

Dimension

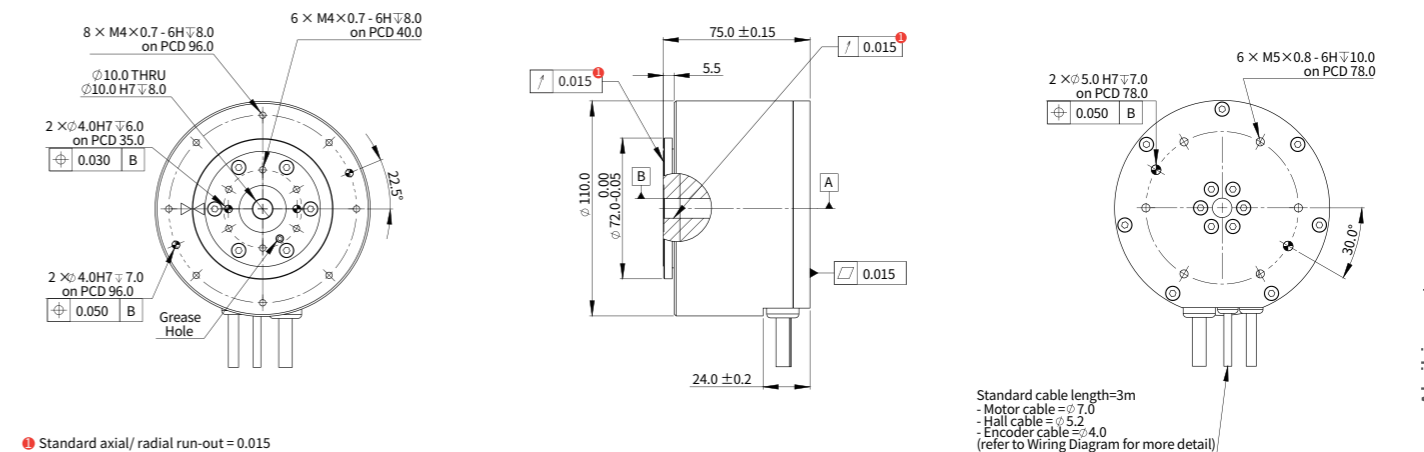

Standard cable length=3m
 - Motor cable = φ7.0
 - Hall cable = φ5.2
 - Encoder cable = φ4.0
 (refer to Wiring Diagram for more detail)

ADR110-A98

ADR110-A98				
Performance Parameters	Symbol	Unit	Series	Parallel
Continuous Torque @100°C	T _{cn}	Nm	4.2	4.2
Peak Torque	T _{pk}	Nm	12.6	12.6
Torque Constant ±10%	K _t	Nm/Arms	1.40	0.70
Back EMF constant ±10%	K _e	Vpeak/rpm	0.119	0.060
Motor Constant @25°C	K _m	Nm/Sqrt(W)	0.51	0.52
Resistance (L-L) @25°C ±10%	R ₂₅	Ω	4.90	1.21
Inductance (L-L) ±20%	L	mH	26.26	6.49
Electrical time constant	τ _e	ms	5.36	5.36
Continuous Current @100°C	I _{cn}	Arms	3.0	6.0
Peak Current	I _{pk}	Arms	9.0	18.0
Continuous Power Dissipation @100°C	P _{cn}	W	85.3	84.2
Max. Coil Temperature	T _{max}	°C	100.0	100.0
Thermal Dissipation Constant	K _{thn}	W/°C	1.1	1.1
Max. Bus Voltage	U _{bus}	Vdc	600.0	600.0
Pole Number	p	-	16	16
Rec. Max Speed @230V AC	Ω _{max}	rpm	1000	2000
Mechanical Parameters				
Overall Mass	m _n	kg	4.60	4.60
Rotor Inertia	J _r	kg·m ²	4.419E-04	4.419E-04
Axial Runout	-	μm	15 (10,5)	15 (10,5)
Radial Runout	-	μm	15 (10,5)	15 (10,5)
Max Axial Load (Upright Mounting)	-	N	700	700
Max Axial Load (Inverted / Wall mounting)	-	N	150	150
Max Moment Load (Upright Mounting)	-	Nm	20	20
Max Moment Load (Inverted / Wall Mounting)	-	Nm	2.2	2.2
Encoder Parameters				
ABI Optical Incremental Encoder (SIN/COS)	-	lines / rev	3005	3005
ABI Optical Incremental Encoder Digital Resolution (80x)	-	counts / rev	240400	240400
ABI Optical Incremental Encoder Digital Resolution (160x)	-	counts / rev	480800	480800
ABI Optical Incremental Encoder Digital Resolution (400x)	-	counts / rev	1202000	1202000
Accuracy with Error Mapping	-	arc sec	+/-5.4	+/-5.4
Repeatability	-	arc sec	+/-2.7	+/-2.7
Other Information				
Insulation Class	Class B (130°C)			
Protection Grade	IP40			
Compliance with Global Standards	RoHS, CE, UL (option)			
Ambient Temperature	Operation	0°C to 40°C (non-freezing)		
	Storage	-15°C to 70°C (non-freezing)		
Ambient Humidity	Operation	10%RH to 80%RH (non-condensing)		
	Storage	10%RH to 90%RH (non-condensing)		
Recommended Ambience	Indoor (no direct sunlight); No corrosive gas, inflammable gas, oil mist or dust.			

- Measurement is taken at ambient temperature 25°C. Value depends on the thermal environment.
 - Resistance is measured by DC current with standard 3 m cable.
 - Inductance is measured by current frequency of 1 kHz.
 - The value is based on ABI optical SIN/COS encoder (4096x interpolation) under maximum bus voltage.
 - The runout value in parenthesis is optional.
 - Please refer to the illustration for different mountings.
 - Based on ABI optical SIN/COS encoder (4096x interpolation) with standard runout.
- The contents of datasheet are subjected to change.

Dimension

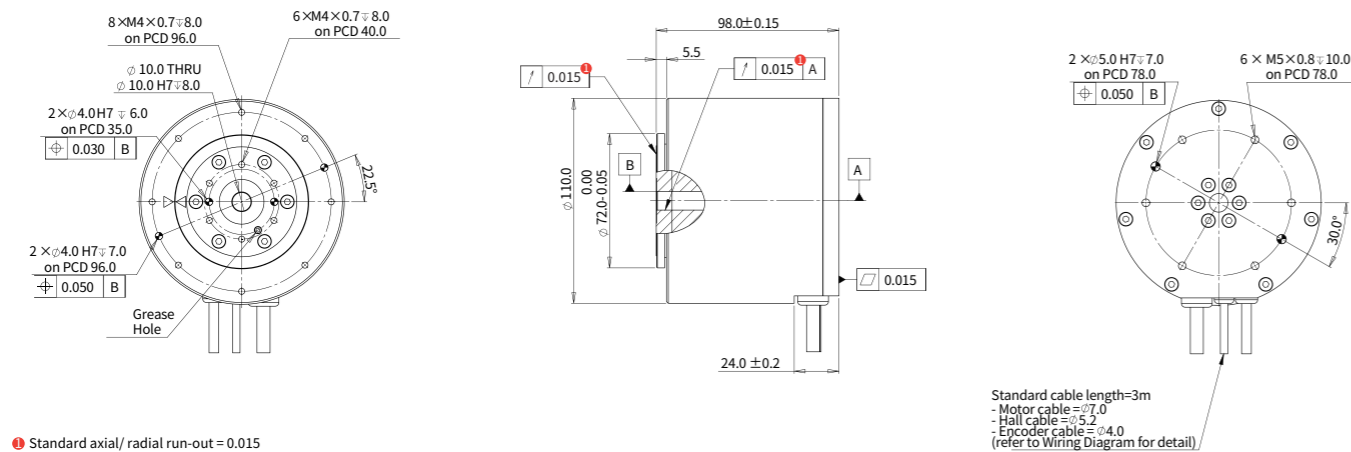

● Standard axial/ radial run-out = 0.015

Torque-Speed Curve

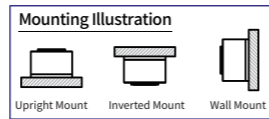
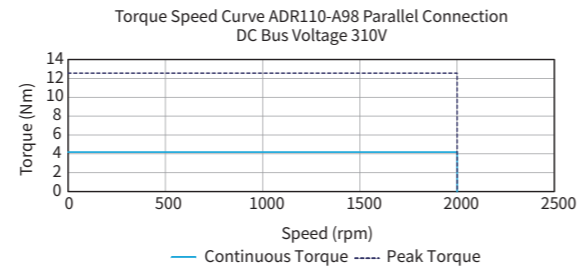
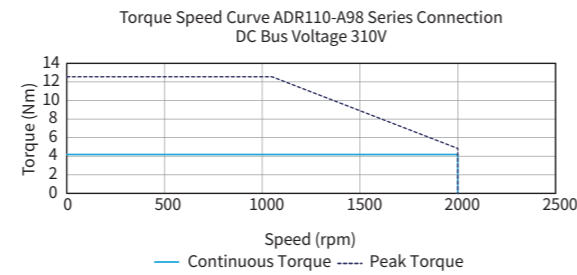

ADR135-A90

ADR135-A90				
Performance Parameters	Symbol	Unit	Series	Parallel
Continuous Torque @100°C	T _{cn}	Nm	5.2	5.2
Peak Torque	T _{pk}	Nm	15.5	15.5
Torque Constant ±10%	K _t	Nm/Arms	1.72	0.86
Back EMF constant ±10%	K _e	Vpeak/rpm	0.147	0.074
Motor Constant @25°C	K _m	Nm/Sqrt(W)	0.55	0.55
Resistance (L-L) @25°C ±10%	R ₂₅	Ω	6.60	1.65
Inductance (L-L) ±20%	L	mH	45.30	11.20
Electrical time constant	τ _e	ms	6.86	6.79
Continuous Current @100°C	I _{cn}	Arms	3.0	6.0
Peak Current	I _{pk}	Arms	9.0	18.0
Continuous Power Dissipation @100°C	P _{cn}	W	114.9	114.9
Max. Coil Temperature	T _{max}	°C	100.0	100.0
Thermal Dissipation Constant	K _{thn}	W/°C	1.5	1.5
Max. Bus Voltage	U _{bus}	Vdc	600.0	600.0
Pole Number	p	-	16	16
Rec. Max Speed @230V AC	Ω _{max}	rpm	630	1350
Mechanical Parameters				
Overall Mass	m _n	kg	4.80	4.80
Rotor Inertia	J _r	kg·m ²	9.916E-04	9.916E-04
Axial Runout	-	μm	15 (10,5)	15 (10,5)
Radial Runout	-	μm	15 (10,5)	15 (10,5)
Max Axial Load (Upright Mounting)	-	N	1050	1050
Max Axial Load (Inverted / Wall mounting)	-	N	180	180
Max Moment Load (Upright Mounting)	-	Nm	35	35
Max Moment Load (Inverted / Wall Mounting)	-	Nm	3.9	3.9
Encoder Parameters				
ABI Optical Incremental Encoder (SIN/COS)	-	lines / rev	3005	3005
ABI Optical Incremental Encoder Digital Resolution (80x)	-	counts / rev	240400	240400
ABI Optical Incremental Encoder Digital Resolution (160x)	-	counts / rev	480800	480800
ABI Optical Incremental Encoder Digital Resolution (400x)	-	counts / rev	1202000	1202000
Accuracy with Error Mapping	-	arc sec	+/-5.4	+/-5.4
Repeatability	-	arc sec	+/-2.7	+/-2.7
Other Information				
Insulation Class	Class B (130°C)			
Protection Grade	IP40			
Compliance with Global Standards	RoHS, CE, UL (option)			
Ambient Temperature	Operation	0°C to 40°C (non-freezing)		
	Storage	-15°C to 70°C (non-freezing)		
Ambient Humidity	Operation	10%RH to 80%RH (non-condensing)		
	Storage	10%RH to 90%RH (non-condensing)		
Recommended Ambience	Indoor (no direct sunlight); No corrosive gas, inflammable gas, oil mist or dust.			

- Measurement is taken at ambient temperature 25°C. Value depends on the thermal environment.
 - Resistance is measured by DC current with standard 3 m cable.
 - Inductance is measured by current frequency of 1 kHz.
 - The value is based on ABI optical SIN/COS encoder (4096x interpolation) under maximum bus voltage.
 - The runout value in parenthesis is optional.
 - Please refer to the illustration for different mountings.
 - Based on ABI optical SIN/COS encoder (4096x interpolation) with standard runout.
- The contents of datasheet are subjected to change.

Dimension

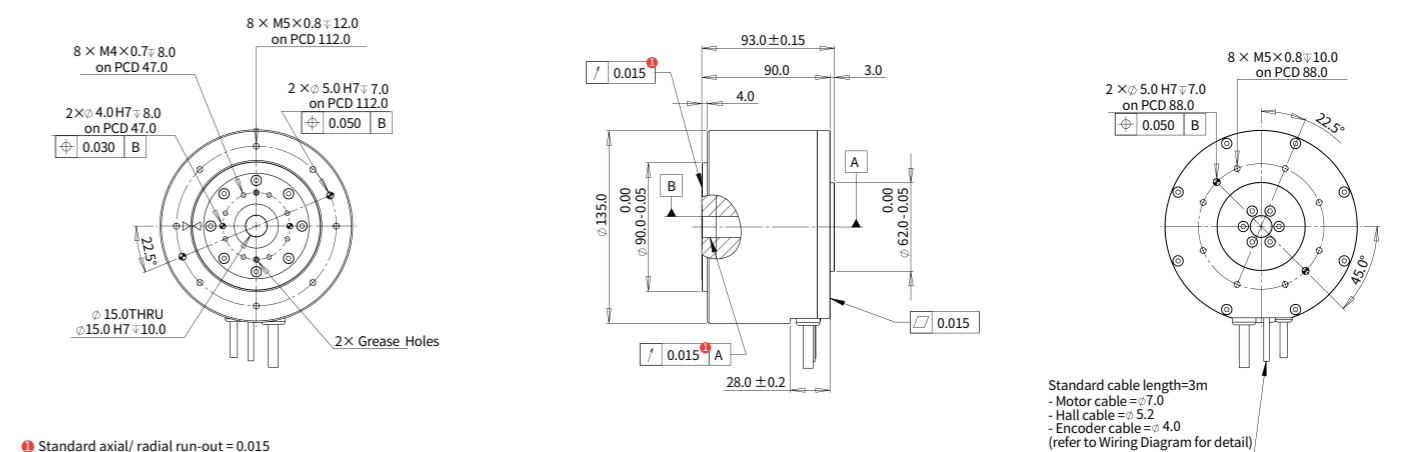

● Standard axial/ radial run-out = 0.015

Torque-Speed Curve

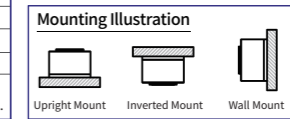
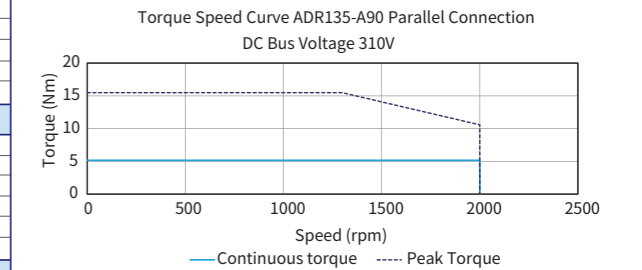
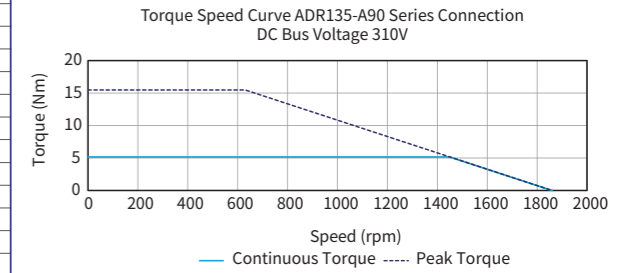

Introduction Sizing Guide Frequently Asked Questions Linear Motors Voice Coil Motors Direct Drive Rotary Motors Motion Control of Gantry Stages Akribis systems

Introduction Sizing Guide Frequently Asked Questions Linear Motors Voice Coil Motors Direct Drive Rotary Motors Motion Control of Gantry Stages Akribis systems

ADR135-A115

ADR135-A115				
Performance Parameters	Symbol	Unit	Series	Parallel
Continuous Torque @100°C	T _{cn}	Nm	11.0	11.0
Peak Torque	T _{pk}	Nm	32.9	32.9
Torque Constant ±10%	K _t	Nm/Arms	3.66	1.83
Back EMF constant ±10%	K _e	Vpeak/rpm	0.313	0.156
Motor Constant @25°C	K _m	Nm/Sqrt(W)	0.91	0.91
Resistance (L-L) @25°C ±10%	R ₂₅	Ω	10.70	2.70
Inductance (L-L) ±20%	L	mH	72.76	18.63
Electrical time constant	τ _e	ms	6.80	6.90
Continuous Current @100°C	I _{cn}	Arms	3.0	6.0
Peak Current	I _{pk}	Arms	9.0	18.0
Continuous Power Dissipation @100°C	P _{cn}	W	186.2	187.9
Max. Coil Temperature	T _{max}	°C	100.0	100.0
Thermal Dissipation Constant	K _{thn}	W/°C	2.5	2.5
Max. Bus Voltage	U _{bus}	Vdc	600.0	600.0
Pole Number	p	-	16	16
Rec. Max Speed @230V AC	Ω _{max}	rpm	330	745
Mechanical Parameters				
Overall Mass	m _n	kg	4.90	4.90
Rotor Inertia	J _r	kg·m ²	1.332E-03	1.332E-03
Axial Runout	-	μm	15 (10,5)	15 (10,5)
Radial Runout	-	μm	15 (10,5)	15 (10,5)
Max Axial Load (Upright Mounting)	-	N	1050	1050
Max Axial Load (Inverted / Wall mounting)	-	N	180	180
Max Moment Load (Upright Mounting)	-	Nm	35	35
Max Moment Load (Inverted / Wall Mounting)	-	Nm	3.9	3.9
Encoder Parameters				
ABI Optical Incremental Encoder (SIN/COS)	-	lines / rev	3005	3005
ABI Optical Incremental Encoder Digital Resolution (80x)	-	counts / rev	240400	240400
ABI Optical Incremental Encoder Digital Resolution (160x)	-	counts / rev	480800	480800
ABI Optical Incremental Encoder Digital Resolution (400x)	-	counts / rev	1202000	1202000
Accuracy with Error Mapping	-	arc sec	+/-5.4	+/-5.4
Repeatability	-	arc sec	+/-2.7	+/-2.7
Other Information				
Insulation Class	Class B (130°C)			
Protection Grade	IP40			
Compliance with Global Standards	RoHS, CE, UL (option)			
Ambient Temperature	Operation	0°C to 40°C (non-freezing)		
	Storage	-15°C to 70°C (non-freezing)		
Ambient Humidity	Operation	10%RH to 80%RH (non-condensing)		
	Storage	10%RH to 90%RH (non-condensing)		
Recommended Ambience	Indoor (no direct sunlight); No corrosive gas, inflammable gas, oil mist or dust.			

- ① Measurement is taken at ambient temperature 25°C. Value depends on the thermal environment.
 - ② Resistance is measured by DC current with standard 3 m cable.
 - ③ Inductance is measured by current frequency of 1 kHz.
 - ④ The value is based on ABI optical SIN/COS encoder (4096x interpolation) under maximum bus voltage.
 - ⑤ The runout value in parenthesis is optional.
 - ⑥ Please refer to the illustration for different mountings.
 - ⑦ Based on ABI optical SIN/COS encoder (4096x interpolation) with standard runout.
- The contents of datasheet are subjected to change.

Dimension

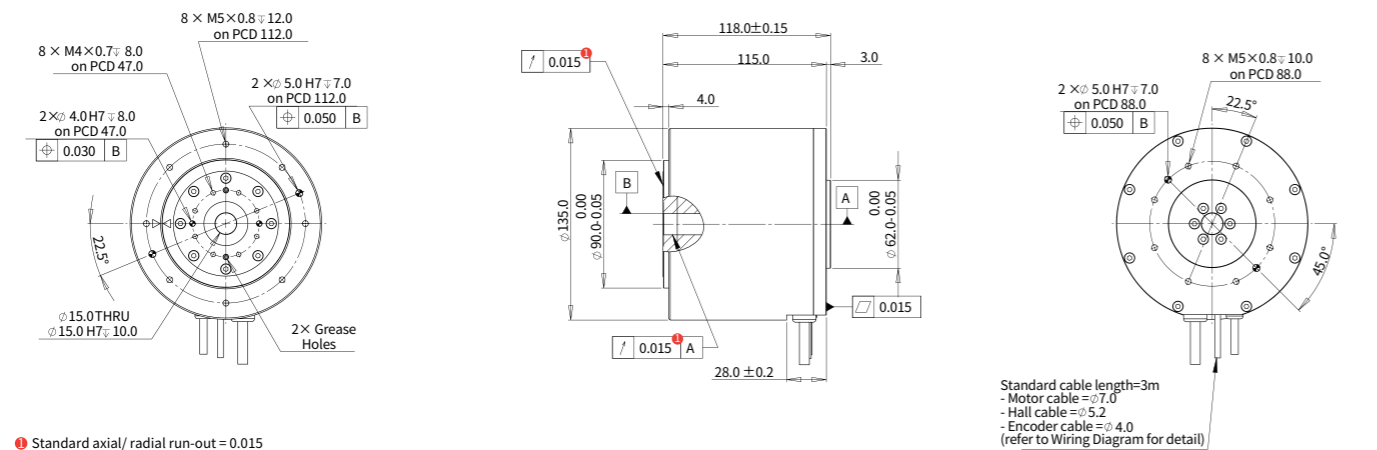

Torque-Speed Curve

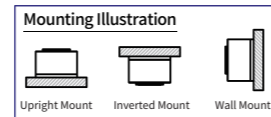
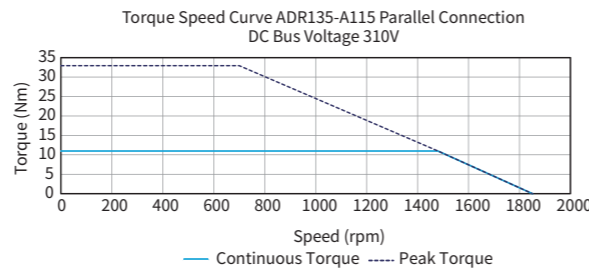
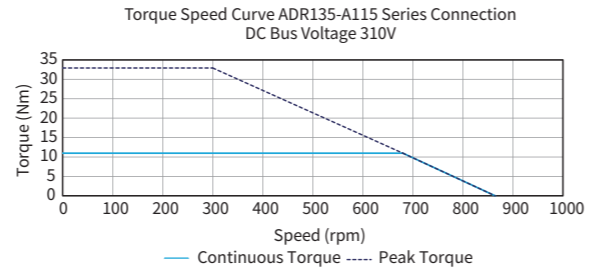

ADR175-A102

ADR175-A102				
Performance Parameters	Symbol	Unit	Series	Parallel
Continuous Torque @100°C	T _{cn}	Nm	15.7	15.7
Peak Torque	T _{pk}	Nm	47.2	47.2
Torque Constant ±10%	K _t	Nm/Arms	3.93	1.97
Back EMF constant ±10%	K _e	Vpeak/rpm	0.336	0.168
Motor Constant @25°C	K _m	Nm/Sqrt(W)	1.40	1.41
Resistance (L-L) @25°C ±10%	R ₂₅	Ω	5.27	1.30
Inductance (L-L) ±20%	L	mH	45.72	11.27
Electrical time constant	τ _e	ms	8.67	8.67
Continuous Current @100°C	I _{cn}	Arms	4.0	8.0
Peak Current	I _{pk}	Arms	12.0	24.0
Continuous Power Dissipation @100°C	P _{cn}	W	163.1	160.9
Max. Coil Temperature	T _{max}	°C	100.0	100.0
Thermal Dissipation Constant	K _{thn}	W/°C	2.2	2.1
Max. Bus Voltage	U _{bus}	Vdc	600.0	600.0
Pole Number	p	-	16	16
Rec. Max Speed @230V AC	Ω _{max}	rpm	400	880
Mechanical Parameters				
Overall Mass	m _n	kg	8.5	8.5
Rotor Inertia	J _r	kg·m ²	5.422E-03	5.422E-03
Axial Runout	-	μm	20 (15,10)	20 (15,10)
Radial Runout	-	μm	20 (15,10)	20 (15,10)
Max Axial Load (Upright Mounting)	-	N	2310	2310
Max Axial Load (Inverted / Wall mounting)	-	N	240	240
Max Moment Load (Upright Mounting)	-	Nm	53	53
Max Moment Load (Inverted / Wall Mounting)	-	Nm	5.8	5.8
Encoder Parameters				
ABI Optical Incremental Encoder (SIN/COS)	-	lines / rev	4103	4103
ABI Optical Incremental Encoder Digital Resolution (80x)	-	counts / rev	328240	328240
ABI Optical Incremental Encoder Digital Resolution (160x)	-	counts / rev	656480	656480
ABI Optical Incremental Encoder Digital Resolution (400x)	-	counts / rev	1641200	1641200
Accuracy with Error Mapping	-	arc sec	+/-4	+/-4
Repeatability	-	arc sec	+/-2	+/-2
Other Information				
Insulation Class	Class B (130°C)			
Protection Grade	IP40			
Compliance with Global Standards	RoHS, CE, UL (option)			
Ambient Temperature	Operation	0°C to 40°C (non-freezing)		
	Storage	-15°C to 70°C (non-freezing)		
Ambient Humidity	Operation	10%RH to 80%RH (non-condensing)		
	Storage	10%RH to 90%RH (non-condensing)		
Recommended Ambience	Indoor (no direct sunlight); No corrosive gas, inflammable gas, oil mist or dust.			

- ① Measurement is taken at ambient temperature 25°C. Value depends on the thermal environment.
 - ② Resistance is measured by DC current with standard 3 m cable.
 - ③ Inductance is measured by current frequency of 1 kHz.
 - ④ The value is based on ABI optical SIN/COS encoder (4096x interpolation) under maximum bus voltage.
 - ⑤ The runout value in parenthesis is optional.
 - ⑥ Please refer to the illustration for different mountings.
 - ⑦ Based on ABI optical SIN/COS encoder (4096x interpolation) with standard runout.
- The contents of datasheet are subjected to change.

Dimension

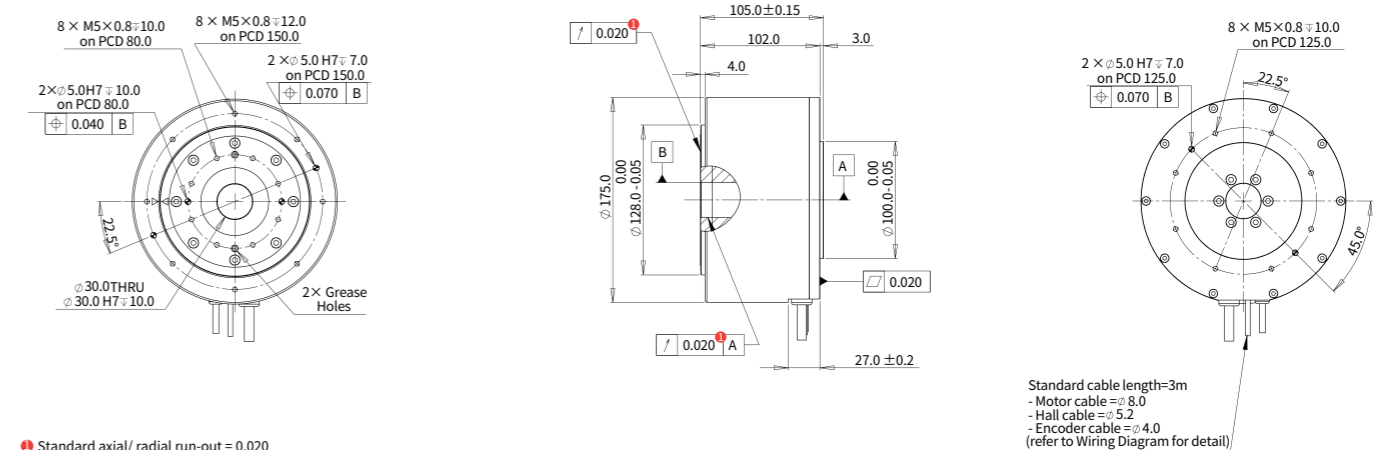

Torque-Speed Curve

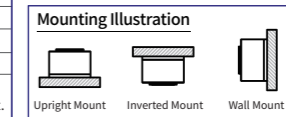
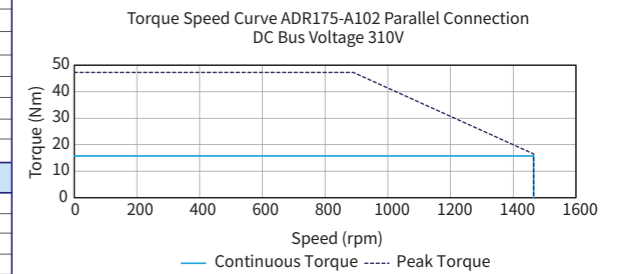
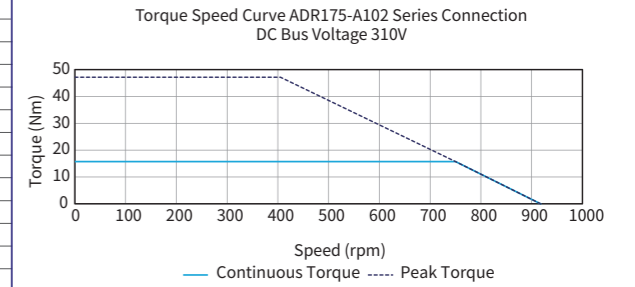

Introduction Sizing Guide Frequently Asked Questions Linear Motors Voice Coil Motors Direct Drive Rotary Motors Motion Control of Gantry Stages Akribis systems

Introduction Sizing Guide Frequently Asked Questions Linear Motors Voice Coil Motors Direct Drive Rotary Motors Motion Control of Gantry Stages Akribis systems

ADR175-A138

ADR175-A138				
Performance Parameters	Symbol	Unit	Series	Parallel
Continuous Torque @100°C	T _{cn}	Nm	32.9	32.9
Peak Torque	T _{pk}	Nm	98.6	98.6
Torque Constant ±10%	K _t	Nm/Arms	8.22	4.11
Back EMF constant ±10%	K _e	Vpeak/rpm	0.703	0.351
Motor Constant @25°C	K _m	Nm/Sqrt(W)	2.33	2.30
Resistance (L-L) @25°C ±10%	R ₂₅	Ω	8.30	2.13
Inductance (L-L) ±20%	L	mH	72.00	18.51
Electrical time constant	τ _e	ms	8.67	8.67
Continuous Current @100°C	I _{cn}	Arms	4.0	8.0
Peak Current	I _{pk}	Arms	12.0	24.0
Continuous Power Dissipation @100°C	P _{cn}	W	256.8	264.2
Max. Coil Temperature	T _{max}	°C	100.0	100.0
Thermal Dissipation Constant	K _{thn}	W/°C	3.4	3.5
Max. Bus Voltage	U _{bus}	Vdc	600.0	600.0
Pole Number	p	-	16	16
Rec. Max Speed @230V AC	Ω _{max}	rpm	195	470

Mechanical Parameters				
Overall Mass	m _n	kg	12.7	12.7
Rotor Inertia	J _r	kg·m ²	7.621E-03	7.621E-03
Axial Runout	-	μm	20 (15,10)	20 (15,10)
Radial Runout	-	μm	20 (15,10)	20 (15,10)
Max Axial Load (Upright Mounting)	-	N	2310	2310
Max Axial Load (Inverted / Wall mounting)	-	N	240	240
Max Moment Load (Upright Mounting)	-	Nm	53	53
Max Moment Load (Inverted / Wall Mounting)	-	Nm	5.8	5.8

Encoder Parameters				
ABI Optical Incremental Encoder (SIN/COS)	-	lines / rev	4103	4103
ABI Optical Incremental Encoder Digital Resolution (80x)	-	counts / rev	328240	328240
ABI Optical Incremental Encoder Digital Resolution (160x)	-	counts / rev	656480	656480
ABI Optical Incremental Encoder Digital Resolution (400x)	-	counts / rev	1641200	1641200
Accuracy with Error Mapping	-	arc sec	+/-4	+/-4
Repeatability	-	arc sec	+/-2	+/-2

Other Information				
Insulation Class	Class B (130°C)			
Protection Grade	IP40			
Compliance with Global Standards	RoHS, CE, UL (option)			
Ambient Temperature	Operation	0°C to 40°C (non-freezing)		
	Storage	-15°C to 70°C (non-freezing)		
Ambient Humidity	Operation	10%RH to 80%RH (non-condensing)		
	Storage	10%RH to 90%RH (non-condensing)		
Recommended Ambience	Indoor (no direct sunlight); No corrosive gas, inflammable gas, oil mist or dust.			

- Measurement is taken at ambient temperature 25°C. Value depends on the thermal environment.
 - Resistance is measured by DC current with standard 3 m cable.
 - Inductance is measured by current frequency of 1 kHz.
 - The value is based on ABI optical SIN/COS encoder (4096x interpolation) under maximum bus voltage.
 - The runout value in parenthesis is optional.
 - Please refer to the illustration for different mountings.
 - Based on ABI optical SIN/COS encoder (4096x interpolation) with standard runout.
- The contents of datasheet are subjected to change.

Dimension

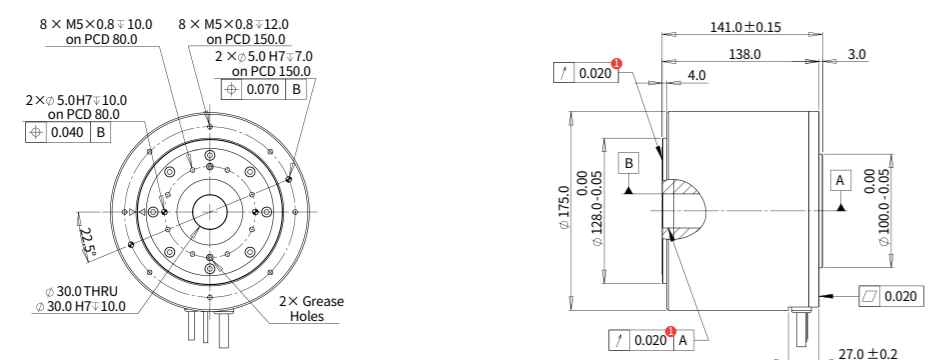

Standard axial/ radial run-out = 0.020

Torque-Speed Curve

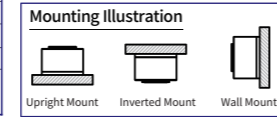
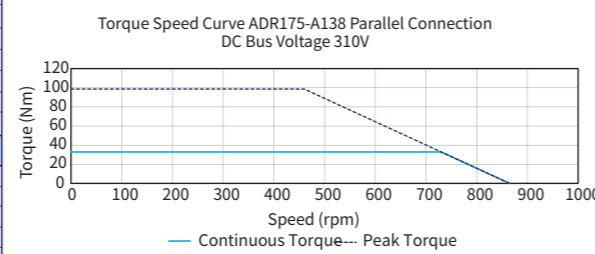
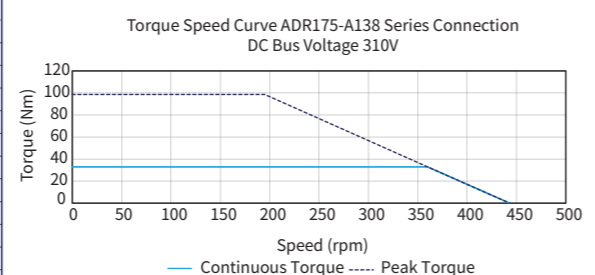

ADR220-A120

ADR220-A120				
Performance Parameters	Symbol	Unit	Series	Parallel
Continuous Torque @100°C	T _{cn}	Nm	46.0	46.0
Peak Torque	T _{pk}	Nm	137.9	137.9
Torque Constant ±10%	K _t	Nm/Arms	8.51	2.84
Back EMF constant ±10%	K _e	Vpeak/rpm	0.727	0.242
Motor Constant @25°C	K _m	Nm/Sqrt(W)	2.87	2.69
Resistance (L-L) @25°C ±10%	R ₂₅	Ω	5.87	0.74
Inductance (L-L) ±20%	L	mH	53.60	6.30
Electrical time constant	τ _e	ms	9.13	8.51
Continuous Current @100°C	I _{cn}	Arms	5.4	16.2
Peak Current	I _{pk}	Arms	16.2	48.6
Continuous Power Dissipation @100°C	P _{cn}	W	331.0	375.5
Max. Coil Temperature	T _{max}	°C	100.0	100.0
Thermal Dissipation Constant	K _{thn}	W/°C	4.4	5.0
Max. Bus Voltage	U _{bus}	Vdc	600.0	600.0
Pole Number	p	-	24	24
Rec. Max Speed @230V AC	Ω _{max}	rpm	150	540

Mechanical Parameters				
Overall Mass	m _n	kg	18.3	18.3
Rotor Inertia	J _r	kg·m ²	1.786E-02	1.786E-02
Axial Runout	-	μm	25 (10)	25 (10)
Radial Runout	-	μm	25 (10)	25 (10)
Max Axial Load (Upright Mounting)	-	N	2800	2800
Max Axial Load (Inverted / Wall mounting)	-	N	300	300
Max Moment Load (Upright Mounting)	-	Nm	72	72
Max Moment Load (Inverted / Wall Mounting)	-	Nm	7.9	7.9

Encoder Parameters				
ABI Optical Incremental Encoder (SIN/COS)	-	lines / rev	4103	4103
ABI Optical Incremental Encoder Digital Resolution (80x)	-	counts / rev	328240	328240
ABI Optical Incremental Encoder Digital Resolution (160x)	-	counts / rev	656480	656480
ABI Optical Incremental Encoder Digital Resolution (400x)	-	counts / rev	1641200	1641200
Accuracy with Error Mapping	-	arc sec	+/-4	+/-4
Repeatability	-	arc sec	+/-2	+/-2

Other Information				
Insulation Class	Class B (130°C)			
Protection Grade	IP40			
Compliance with Global Standards	RoHS, CE, UL (option)			
Ambient Temperature	Operation	0°C to 40°C (non-freezing)		
	Storage	-15°C to 70°C (non-freezing)		
Ambient Humidity	Operation	10%RH to 80%RH (non-condensing)		
	Storage	10%RH to 90%RH (non-condensing)		
Recommended Ambience	Indoor (no direct sunlight); No corrosive gas, inflammable gas, oil mist or dust.			

- Measurement is taken at ambient temperature 25°C. Value depends on the thermal environment.
 - Resistance is measured by DC current with standard 3 m cable.
 - Inductance is measured by current frequency of 1 kHz.
 - The value is based on ABI optical SIN/COS encoder (4096x interpolation) under maximum bus voltage.
 - The runout value in parenthesis is optional.
 - Please refer to the illustration for different mountings.
 - Based on ABI optical SIN/COS encoder (4096x interpolation) with standard runout.
- The contents of datasheet are subjected to change.

Dimension

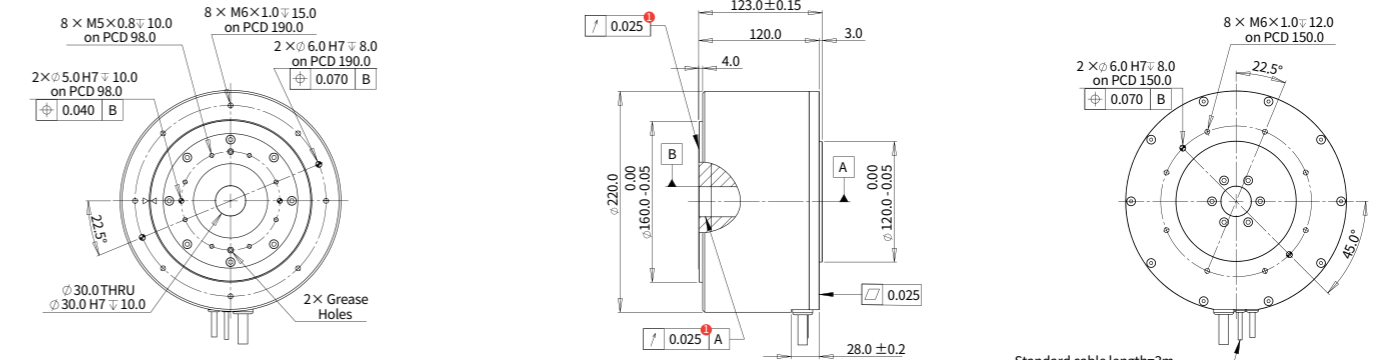

Standard axial/ radial run-out = 0.025

Torque-Speed Curve

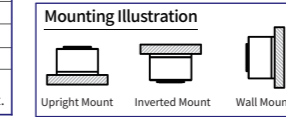
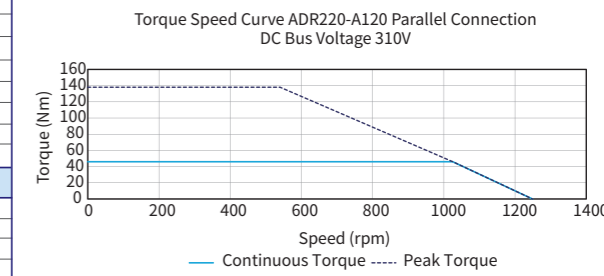
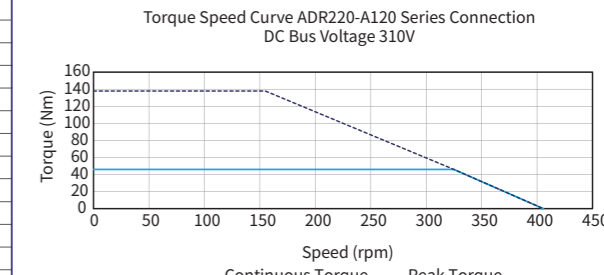

Introduction Sizing Guide Frequently Asked Questions Linear Motors Voice Coil Motors Direct Drive Rotary Motors Motion Control of Gantry Stages

Introduction Sizing Guide Frequently Asked Questions Linear Motors Voice Coil Motors Direct Drive Rotary Motors Motion Control of Gantry Stages

ADR220-A165

ADR220-A165				
Performance Parameters	Symbol	Unit	Series	Parallel
Continuous Torque @100°C	T _{cn}	Nm	94.9	94.9
Peak Torque	T _{pk}	Nm	284.6	284.6
Torque Constant ±10%	K _t	Nm/Arms	17.57	5.86
Back EMF constant ±10%	K _e	Vpeak/rpm	1.502	0.501
Motor Constant @25°C	K _m	Nm/Sqrt(W)	4.47	4.37
Resistance (L-L) @25°C ±10%	R ₂₅	Ω	10.32	1.20
Inductance (L-L) ±20%	L	mH	106.70	11.90
Electrical time constant	τ _e	ms	10.34	9.92
Continuous Current @100°C	I _{cn}	Arms	5.4	16.2
Peak Current	I _{pk}	Arms	16.2	48.6
Continuous Power Dissipation @100°C	P _{cn}	W	581.9	608.9
Max. Coil Temperature	T _{max}	°C	100.0	100.0
Thermal Dissipation Constant	K _{thn}	W/°C	7.8	8.1
Max. Bus Voltage	U _{bus}	Vdc	600.0	600.0
Pole Number	p	-	24	24
Rec. Max Speed @230V AC	Ω _{max}	rpm	50	260
Mechanical Parameters				
Overall Mass	m _n	kg	24.1	24.1
Rotor Inertia	J _r	kg·m ²	2.522E-02	2.522E-02
Axial Runout	-	μm	25 (10)	25 (10)
Radial Runout	-	μm	25 (10)	25 (10)
Max Axial Load (Upright Mounting)	-	N	2800	2800
Max Axial Load (Inverted / Wall mounting)	-	N	300	300
Max Moment Load (Upright Mounting)	-	Nm	72	72
Max Moment Load (Inverted / Wall Mounting)	-	Nm	7.9	7.9
Encoder Parameters				
ABI Optical Incremental Encoder (SIN/COS)	-	lines / rev	4103	4103
ABI Optical Incremental Encoder Digital Resolution (80x)	-	counts / rev	328240	328240
ABI Optical Incremental Encoder Digital Resolution (160x)	-	counts / rev	656480	656480
ABI Optical Incremental Encoder Digital Resolution (400x)	-	counts / rev	1641200	1641200
Accuracy with Error Mapping	-	arc sec	+/-4	+/-4
Repeatability	-	arc sec	+/-2	+/-2
Other Information				
Insulation Class	Class B (130°C)			
Protection Grade	IP40			
Compliance with Global Standards	RoHS, CE, UL (option)			
Ambient Temperature	Operation	0°C to 40°C (non-freezing)		
	Storage	-15°C to 70°C (non-freezing)		
Ambient Humidity	Operation	10%RH to 80%RH (non-condensing)		
	Storage	10%RH to 90%RH (non-condensing)		
Recommended Ambience	Indoor (no direct sunlight); No corrosive gas, inflammable gas, oil mist or dust.			

- ① Measurement is taken at ambient temperature 25°C. Value depends on the thermal environment.
 - ② Resistance is measured by DC current with standard 3 m cable.
 - ③ Inductance is measured by current frequency of 1 kHz.
 - ④ The value is based on ABI optical SIN/COS encoder (4096x interpolation) under maximum bus voltage.
 - ⑤ The runout value in parenthesis is optional.
 - ⑥ Please refer to the illustration for different mountings.
 - ⑦ Based on ABI optical SIN/COS encoder (4096x interpolation) with standard runout.
- The contents of datasheet are subjected to change.

Dimension

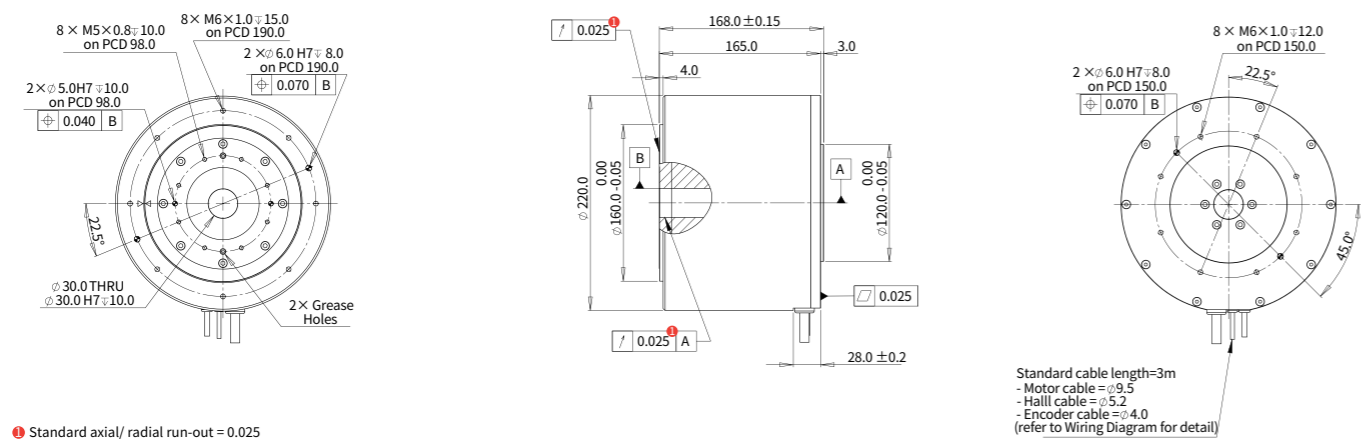

① Standard axial/ radial run-out = 0.025

Torque-Speed Curve

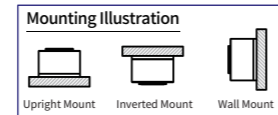
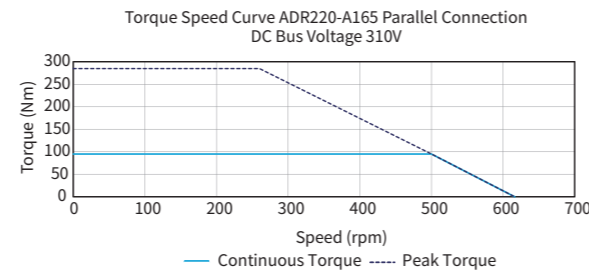
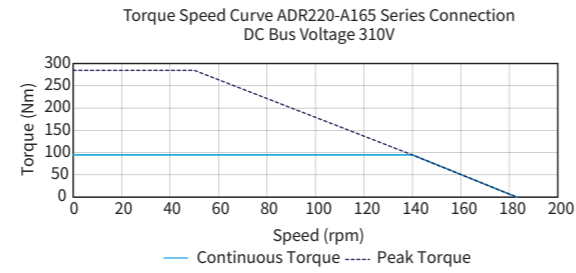

ADR360-A150

ADR360-A150				
Performance Parameters	Symbol	Unit	Series	Parallel
Continuous Torque @100°C	T _{cn}	Nm	184.8	184.8
Peak Torque	T _{pk}	Nm	554.5	554.5
Torque Constant ±10%	K _t	Nm/Arms	18.48	9.24
Back EMF constant ±10%	K _e	Vpeak/rpm	1.580	0.790
Motor Constant @25°C	K _m	Nm/Sqrt(W)	8.64	8.64
Resistance (L-L) @25°C ±10%	R ₂₅	Ω	3.05	0.76
Inductance (L-L) ±20%	L	mH	31.70	7.92
Electrical time constant	τ _e	ms	10.40	10.40
Continuous Current @100°C	I _{cn}	Arms	10.0	20.0
Peak Current	I _{pk}	Arms	30.0	60.0
Continuous Power Dissipation @100°C	P _{cn}	W	589.3	589.3
Max. Coil Temperature	T _{max}	°C	100.0	100.0
Thermal Dissipation Constant	K _{thn}	W/°C	7.9	7.9
Max. Bus Voltage	U _{bus}	Vdc	600.0	600.0
Pole Number	p	-	32	32
Rec. Max Speed @230V AC	Ω _{max}	rpm	90	220
Mechanical Parameters				
Overall Mass	m _n	kg	56.0	56.0
Rotor Inertia	J _r	kg·m ²	2.046E-01	2.046E-01
Axial Runout	-	μm	40 (15)	40 (15)
Radial Runout	-	μm	40 (15)	40 (15)
Max Axial Load (Upright Mounting)	-	N	11200	11200
Max Axial Load (Inverted / Wall mounting)	-	N	350	350
Max Moment Load (Upright Mounting)	-	Nm	245	245
Max Moment Load (Inverted / Wall Mounting)	-	Nm	27.0	27.0
Encoder Parameters				
ABI Optical Incremental Encoder (SIN/COS)	-	lines / rev	7500	7500
ABI Optical Incremental Encoder Digital Resolution (80x)	-	counts / rev	600000	600000
ABI Optical Incremental Encoder Digital Resolution (160x)	-	counts / rev	1200000	1200000
ABI Optical Incremental Encoder Digital Resolution (400x)	-	counts / rev	3000000	3000000
Accuracy with Error Mapping	-	arc sec	+/-4	+/-4
Repeatability	-	arc sec	+/-2	+/-2
Other Information				
Insulation Class	Class B (130°C)			
Protection Grade	IP40			
Compliance with Global Standards	RoHS, CE, UL (option)			
Ambient Temperature	Operation	0°C to 40°C (non-freezing)		
	Storage	-15°C to 70°C (non-freezing)		
Ambient Humidity	Operation	10%RH to 80%RH (non-condensing)		
	Storage	10%RH to 90%RH (non-condensing)		
Recommended Ambience	Indoor (no direct sunlight); No corrosive gas, inflammable gas, oil mist or dust.			

- ① Measurement is taken at ambient temperature 25°C. Value depends on the thermal environment.
 - ② Resistance is measured by DC current with standard 3 m cable.
 - ③ Inductance is measured by current frequency of 1 kHz.
 - ④ The value is based on ABI optical SIN/COS encoder (4096x interpolation) under maximum bus voltage.
 - ⑤ The runout value in parenthesis is optional.
 - ⑥ Please refer to the illustration for different mountings.
 - ⑦ Based on ABI optical SIN/COS encoder (4096x interpolation) with standard runout.
- The contents of datasheet are subjected to change.

Dimension

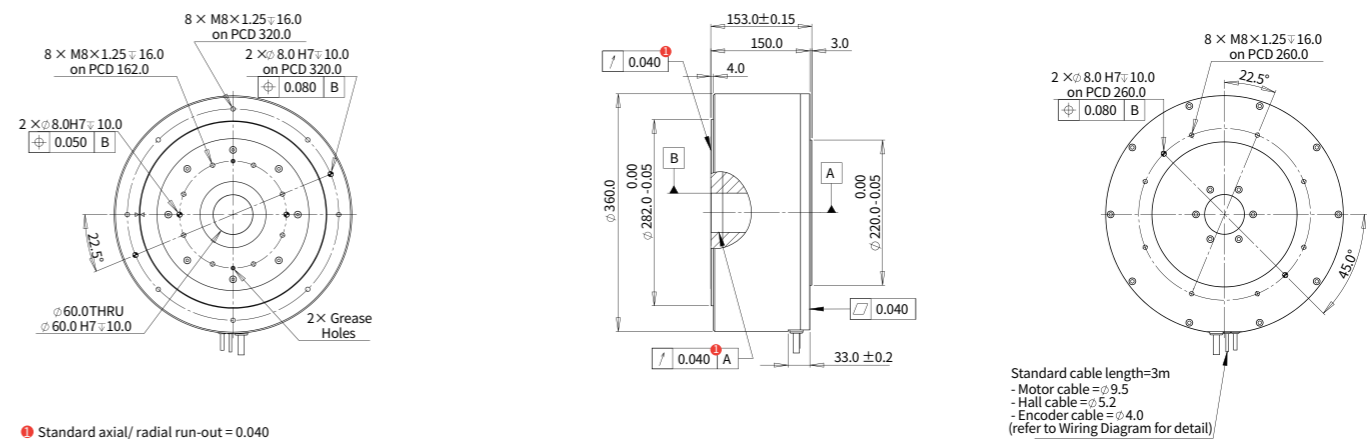

① Standard axial/ radial run-out = 0.040

Torque-Speed Curve

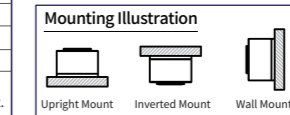
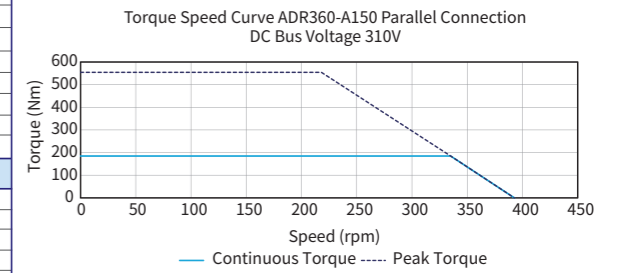
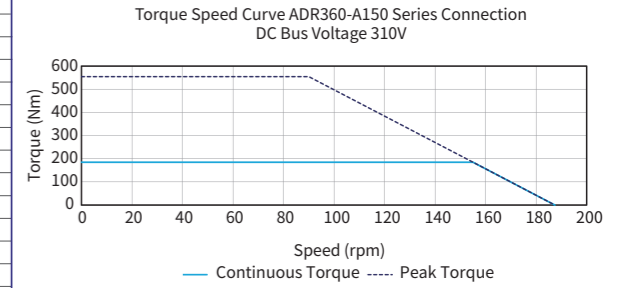

ADR360-A215

ADR360-A215				
Performance Parameters	Symbol	Unit	Series	Parallel
Continuous Torque @100°C	T _{cn}	Nm	377.9	377.9
Peak Torque	T _{pk}	Nm	1133.8	1133.8
Torque Constant ±10%	K _t	Nm/Arms	37.79	18.90
Back EMF constant ±10%	K _e	Vpeak/rpm	3.230	1.615
Motor Constant @25°C	K _m	Nm/Sqrt(W)	13.45	13.80
Resistance (L-L) @25°C ±10%	R ₂₅	Ω	5.26	1.25
Inductance (L-L) ±20%	L	mH	54.74	13.00
Electrical time constant	τ _e	ms	10.40	10.40
Continuous Current @100°C	I _{cn}	Arms	10.0	20.0
Peak Current	I _{pk}	Arms	30.0	60.0
Continuous Power Dissipation @100°C	P _{cn}	W	1017.8	966.8
Max. Coil Temperature	T _{max}	°C	100.0	100.0
Thermal Dissipation Constant	K _{thn}	W/°C	13.6	12.9
Max. Bus Voltage	U _{bus}	Vdc	600.0	600.0
Pole Number	p	-	32	32
Rec. Max Speed @230V AC	Ω _{max}	rpm	30	105

Mechanical Parameters				
Overall Mass	m _n	kg	71.0	71.0
Rotor Inertia	J _r	kg·m ²	3.223E-01	3.223E-01
Axial Runout	-	μm	40 (15)	40 (15)
Radial Runout	-	μm	40 (15)	40 (15)
Max Axial Load (Upright Mounting)	-	N	11200	11200
Max Axial Load (Inverted / Wall mounting)	-	N	350	350
Max Moment Load (Upright Mounting)	-	Nm	245	245
Max Moment Load (Inverted / Wall Mounting)	-	Nm	27.0	27.0

Encoder Parameters				
ABI Optical Incremental Encoder (SIN/COS)	-	lines / rev	7500	7500
ABI Optical Incremental Encoder Digital Resolution (80x)	-	counts / rev	600000	600000
ABI Optical Incremental Encoder Digital Resolution (160x)	-	counts / rev	1200000	1200000
ABI Optical Incremental Encoder Digital Resolution (400x)	-	counts / rev	3000000	3000000
Accuracy with Error Mapping	-	arc sec	+/-4	+/-4
Repeatability	-	arc sec	+/-2	+/-2

Other Information				
Insulation Class	Class B (130°C)			
Protection Grade	IP40			
Compliance with Global Standards	RoHS, CE, UL (option)			
Ambient Temperature	Operation	0°C to 40°C (non-freezing)		
	Storage	-15°C to 70°C (non-freezing)		
Ambient Humidity	Operation	10%RH to 80%RH (non-condensing)		
	Storage	10%RH to 90%RH (non-condensing)		
Recommended Ambience	Indoor (no direct sunlight); No corrosive gas, inflammable gas, oil mist or dust.			

- ① Measurement is taken at ambient temperature 25°C. Value depends on the thermal environment.
 - ② Resistance is measured by DC current with standard 3m cable.
 - ③ Inductance is measured by current frequency of 1 kHz.
 - ④ The value is based on ABI optical SIN/COS encoder (4096x interpolation) under maximum bus voltage.
 - ⑤ The runout value in parenthesis is optional.
 - ⑥ Please refer to the illustration for different mountings.
 - ⑦ Based on ABI optical SIN/COS encoder (4096x interpolation) with standard runout.
- The contents of datasheet are subjected to change.

Dimension

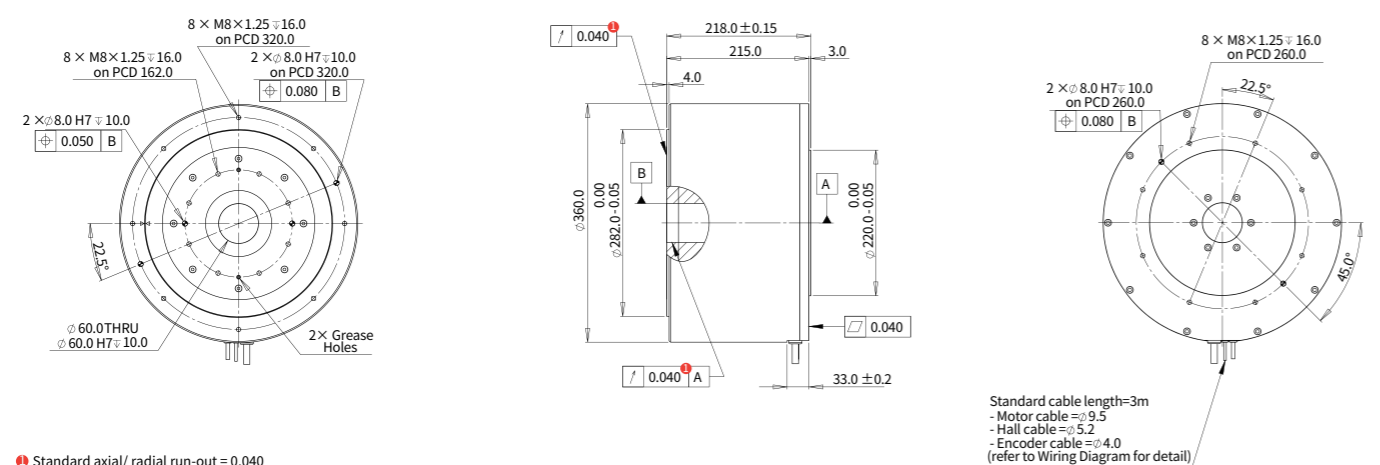

① Standard axial/ radial run-out = 0.040

Torque-Speed Curve

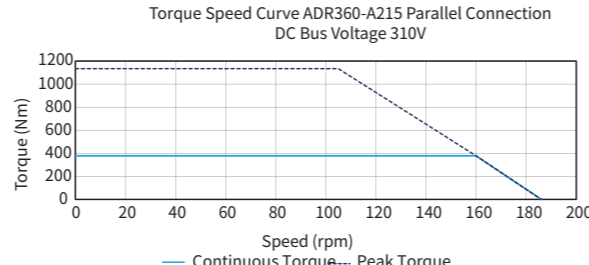
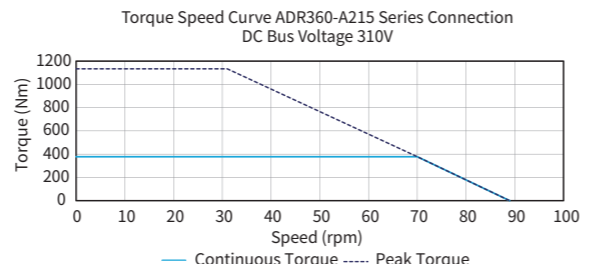

Mounting Illustration

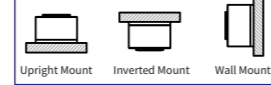

Motor Cable Connection

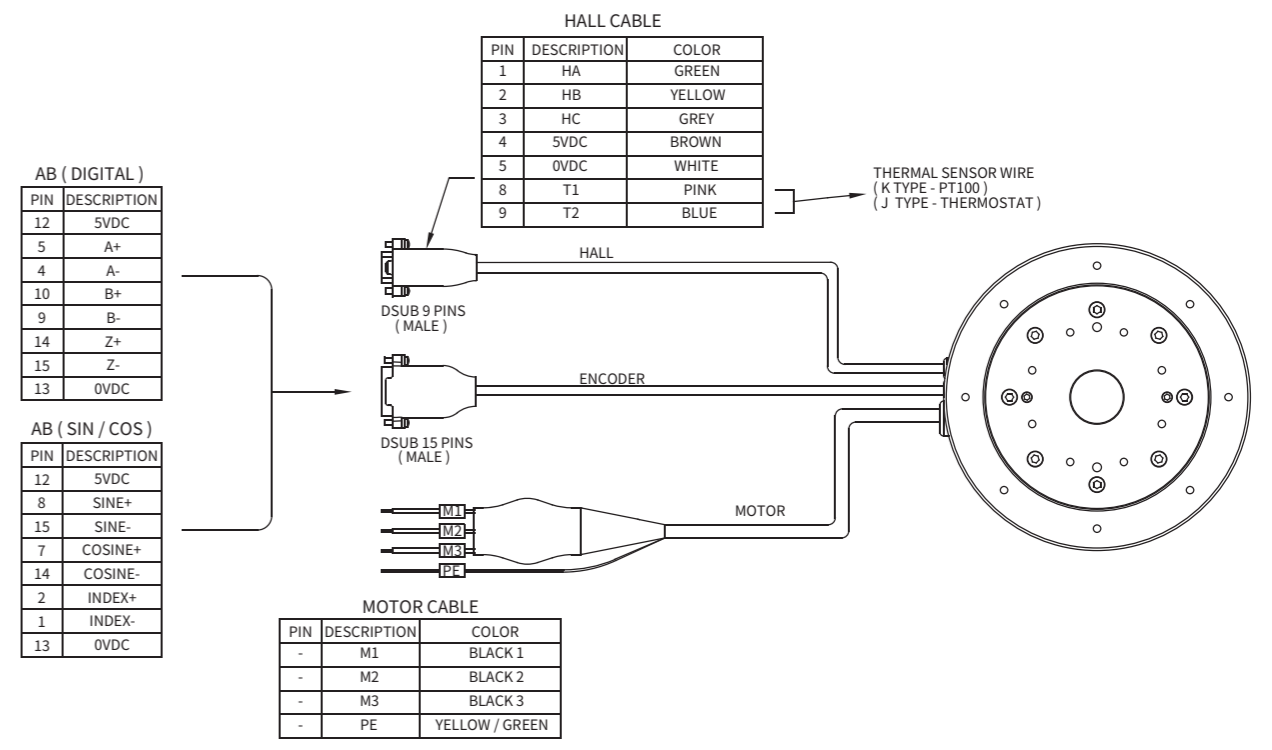

Part Numbering

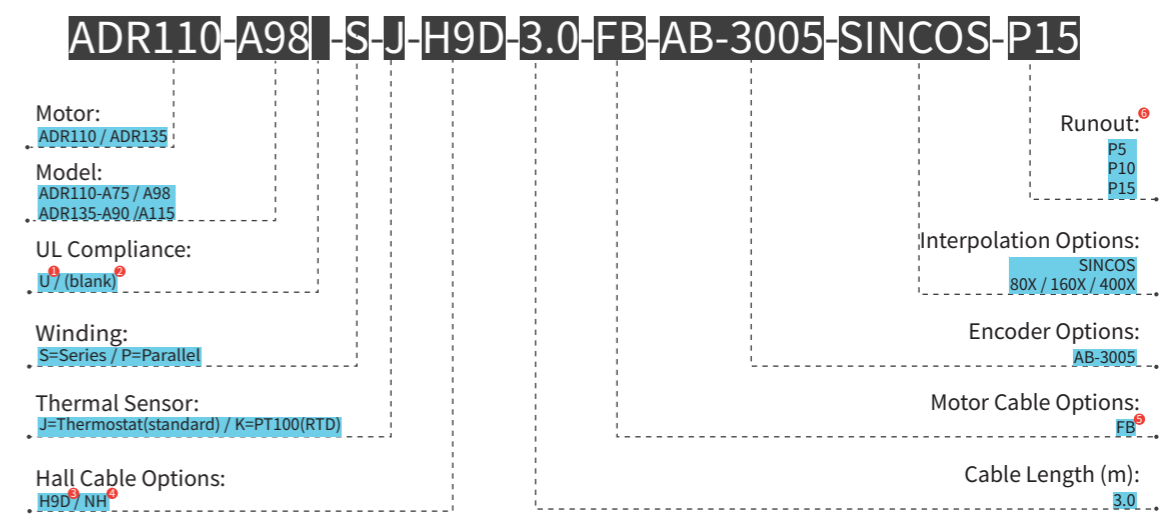

- ① U=UL-complied version (and CE-complied)
- ② (blank)= standard, only CE-complied
- ③ H9D= With Built-in hall sensor, comes with 9-Pins D-Sub Connector
- ④ NH= Without Built-in Hall Sensor but with Thermal Sensor
- ⑤ FB = With ferrite bead
- ⑥ P5 = Axial Runout 5um, Radial Runout is 5um.
- ⑦ P10 = Axial Runout 10um, Radial Runout is 10um
- ⑧ P15=Axial Runout 15um, Radial Runout is 15um.

Introduction Sizing Guide Frequently Asked Questions Linear Motors Voice Coil Motors Direct Drive Rotary Motors Motion Control of Gantry Stages Akribis systems

Introduction Sizing Guide Frequently Asked Questions Linear Motors Voice Coil Motors Direct Drive Rotary Motors Motion Control of Gantry Stages Akribis systems

ADR175-A138-S-J-H9D-3.0-FB-AB-4103-80X-P10

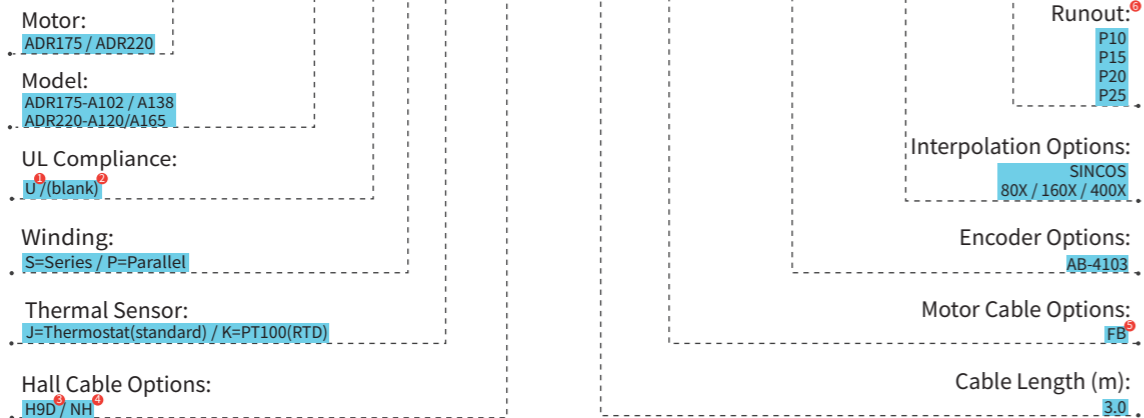

- ① U=UL-complied version (and CE-complied)
- ② (blank)= standard, only CE-complied
- ③ H9D= With Built-in hall sensor, comes with 9-Pins D-Sub Connector
- ④ NH= Without Built-in Hall Sensor but with Thermal Sensor
- ⑤ FB = With ferrite bead
- ⑥ ADR175 / ADR220 : P10 = Axial Runout 10um, Radial Runout is 10um
ADR175 : P15=Axial Runout 15um, Radial Runout is 15um.
ADR175 : P20 = Axial Runout 20um, Radial Runout is 20um.
ADR220 : P25 = Axial Runout 25um, Radial Runout is 25um.

ADR360-A150-S-J-H9D-3.0-FB-AB-7500-400X-P15

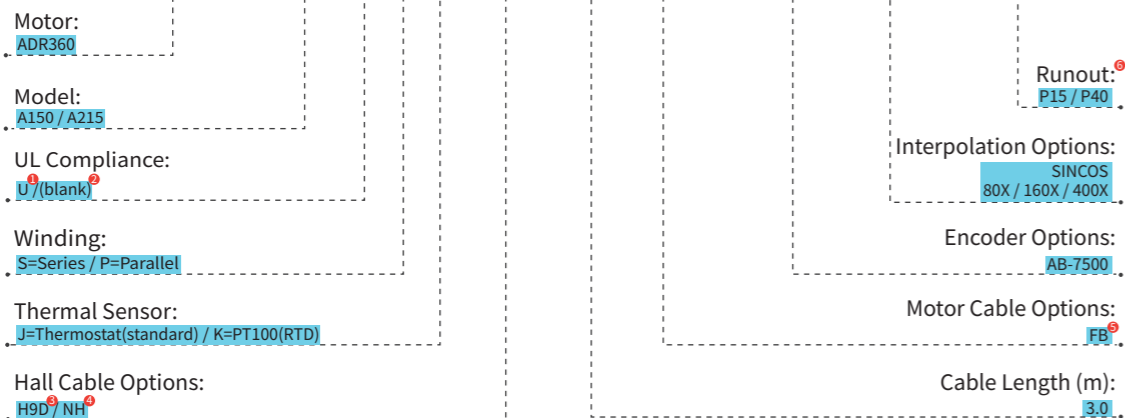

- ① U=UL-complied version (and CE-complied)
- ② (blank)= standard, only CE-complied
- ③ H9D= With Built-in hall sensor, comes with 9-Pins D-Sub Connector
- ④ NH= Without Built-in Hall Sensor but with Thermal Sensor
- ⑤ FB = With ferrite bead
- ⑥ P15=Axial Runout 15um, Radial Runout is 15um.
P40=Axial Runout 40um, Radial Runout is 40um.

