

Kollmorgen Automation Suite™ Catalog

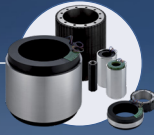

Cartridge DDR™ Motors



Frameless Brushless Direct Drive Motors



Housed DDR™ Motors



AKD®-N Decentralized Servo Drive

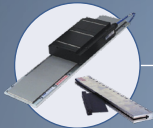

Direct Drive Linear Motors



Linear Positioners



Multi-Axis Precision Tables

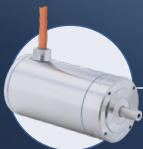

AKMH™ Hygienic Stainless Steel Motors



AKM® Servomotors



AKI Touch Panels

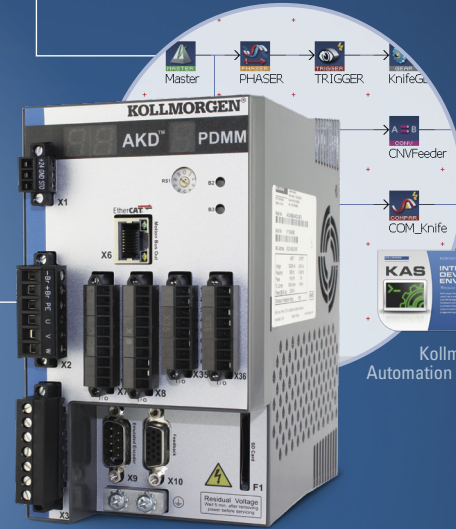

AKD® PDMM Programmable Automation Controller, PAC and Servo Drive



Kollmorgen Automation Suite™ (KAS)

KOLLMORGEN®

Because Motion Matters™

Kollmorgen: Your partner. In Motion.

Every solution comes from a real understanding of the challenges facing machine designers and users.

Innovators consistently rate Kollmorgen as one of their best motion systems manufacturing partners. Whether you are looking for classic servo motors, direct-drive servo motors, stepper motors, drives & amplifiers, gearing, actuation, or CNC & multi-axis motion controllers, Kollmorgen is one of the few companies in the world who actually designs and manufactures all of these products.

Our customers are leaders in many industries such as Aerospace & Defense, Printing, Packaging & Converting, Food & Beverage Processing, Medical Imaging, In Vitro Diagnostics & Laboratory Automation, Pharmaceutical Manufacturing, Material Forming and Cutting, Oil & Gas, and Robotics. Kollmorgen is also a leader in Warehouse Automation, including complete AGV systems, software, awareness and autonomy.

Our Automation Solutions can be found on Mars and in space, ships and submarines, O&G drilling and metrology, surgical robots and laser eye surgery, even inside artificial hearts. These are just a few applications that demand high-performance and high-quality while satisfying their specific needs.

Because motion matters, it's our focus: Motion can distinctly differentiate a machine and deliver a marketplace advantage by increasing its performance and dramatically improving overall equipment effectiveness (OEE).

High-performance motion can make your customer's machine more reliable and energy-efficient, enhance accuracy and improve operator safety. Motion also represents endless possibilities for innovation.

We've always understood this potential, and thus have kept motion at our core and in our Vision, Mission & Values, relentlessly developing products that offer precise control of torque, velocity and position accuracy in machines that rely on complex motion.

Removing the Barriers of Design, Sourcing, and Time

At Kollmorgen, we know that OEM engineers can achieve a lot more when obstacles aren't in the way. So, we clear obstacles in three important ways:

Integrating Standard and Custom Products

The optimal solution is often not clear-cut. Our application expertise allows us to modify standard products or develop totally custom solutions across our whole product portfolio so that designs can take flight.

Providing Motion Solutions, Not Just Components

As companies reduce their supplier base and have less engineering manpower, they need a total system supplier with a wide range of integrated solutions. Kollmorgen offers complete solutions as well as motion subsystems that combine programming software, engineering services and best-in-class motion components.

Global Footprint

With direct sales, engineering support, manufacturing facilities, and distributors spanning the Americas, Europe, Middle East, and Asia, we're close to OEMs worldwide. Our proximity helps speed delivery and lend support where and when they're needed.

Financial and Operational Stability

Kollmorgen is part of Fortive. A key driver in the growth of all Fortive divisions is the Fortive Business System, which relies on the principle of "kaizen" – or continuous improvement. Using world-class tools, cross-disciplinary teams of exceptional people evaluate processes and develop plans that result in superior performance.

Kollmorgen: Your partner. In Motion.

Table of Contents

- ▶ **Kollmorgen Automation Suite™** 4
- Scalable Programability** 8
- Development** 10
- Life Cycle** 11
- Software PLC** 12
- Motion Programming** 14
- AKD® PDMM Drive Resident Controller** 16
- PCMM Stand-Alone Controller** 18
- Real-time Motion Bus** 20
- Human Machine Interface** 21
- I/O Terminals** 24
- Kollmorgen Developer Network** 25
- ▶ **Custom Capabilities** 26
- ▶ **MOTIONEERING® Online** 27

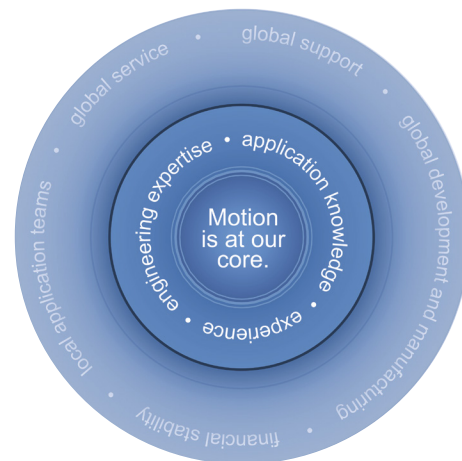

Kollmorgen Automation Suite™

Kollmorgen's machine automation platform dramatically simplifies how you approach the many complex automation challenges of today's machines. We have created an integrated development environment (IDE) that greatly simplifies programming and system configuration and combines multiple tools into one intuitive platform, we have global support and experienced engineering services to solve your biggest challenges, and our best-in-class automation and motion components deliver unparalleled motion performance; all of which combine to help you create a differentiated machine, get to market faster, and have the comfort and ease of collaborating with just one vendor.

Integrated Development Environment – Quickly and easily design, refine and troubleshoot all of a machine's automated solutions in this highly intuitive application featuring a single programming environment that provides great flexibility and control.

Engineering Services – A Kollmorgen representative establishes a collaborative, consultative relationship from the beginning by assessing needs and objectives. Field engineers and application engineers constantly support the design and build phase as well as the factory installation phase to ensure that your needs are met from concept to production. Additional services are available that include development, on-site deployment, and training.

Best-in-Class Automation and Motion Components – With Kollmorgen, there's security in knowing the necessary components that form the building blocks of a machine are always available. No one offers a wider range of standard, modified standard and custom products. Motion is at the core of our Automation Suite, where others in the industry consider it an add-on.

Kollmorgen Co-engineering – More than a solutions provider, we co-engineer a better fit with your company using both products and services. From a wide breadth of product modifications, over 500,000 standard options with 5-day delivery on our AKM® line, to aftermarket revenue protection and training programs, Kollmorgen co-engineering helps you differentiate your machine and business.

We accept your challenges as our own. That's the Kollmorgen co-engineering difference.

The Advantages of Kollmorgen Automation Suite™

- High machine performance
 - Up to 25% greater throughput
 - Up to 50% scrap reduction
 - Improved accuracy
 - Advanced drive technology for machines with outstanding performance
- Fast to market
 - Up to 30% reduction in development time
 - Services available for program development, training, start-up, and support
 - Industry standard programming environment and industrial networks
- Enhanced ease-of-use and integration
 - Single integrated programming environment for automation, drive technology, and all hardware
 - Drag-and-drop motion programming
 - Certified components that are tested to work together
 - Seamless integration and configuration of amplifiers for optimal set-up
- A demonstrated solution
 - The result of over 20 years of permanent optimization of programming and implementing automation and drive solutions
 - Provides the diverse experience of a great number of suppliers and platforms that form today's Kollmorgen
 - Used successfully for more than 6 years

Kollmorgen Automation Suite™

Integrated Software and Hardware System for Efficient Drive Design

Using the components of the Kollmorgen Automation Suite, you develop better drives in less time. The comprehensive control system solution comprises all the components for system design, programming, display, testing, and start-up. In terms of hardware, the AKD® PDMM – the 3-in-1 solution with integrated servo drive, motion controller, and PLC – is the central component in the machine.

KOLLMORGEN AUTOMATION SUITE



Cartridge DDR™ Motors

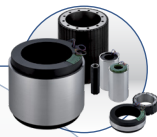

Frameless Brushless Direct Drive Motors

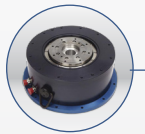

Housed DDR™ Motors

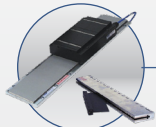

Direct Drive Linear Motors

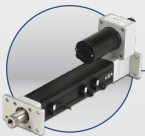

Linear Positioners

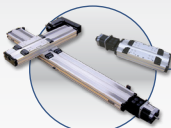

Multi-Axis Precision Tables



AKMH™ Hygienic Stainless Steel Motors

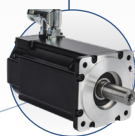

AKM® Servomotors

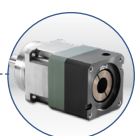

Micron® Gearheads



AKD®-N Decentralized Servo Drive



AKD® Servo Drives



System programming with the Pipe-Network™ or PLCopen



AKI touch panels operate and display



Control of motors with AKD® PDMM programmable multi-axis master

Interface diversity: I/O bus terminals AKT - Advanced Kollmorgen Terminals

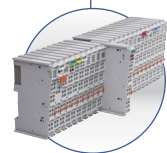

Diverse and Scalable Drive Solutions

Need more axes? Different motor outputs? Linear direct drives here, direct drives with no housing there? No problem! With the EtherCAT® system bus you can connect more AKD® servo drives and add motors of all performance classes from the Kollmorgen product range.

Interfaces are frequently the bottleneck in system design. Not so with the Kollmorgen Automation Suite. With the Advanced Kollmorgen Terminals (AKT) IO bus terminals and the EtherCAT® bus coupler, you possess a flexible interface system which leaves nothing to be desired.

Control and monitor the processes on the machine with the AKI series touch panels. With the Kollmorgen Visualization Builder (KVB), you can program ergonomic user interfaces which guarantee safe handling and displays machine data clearly.

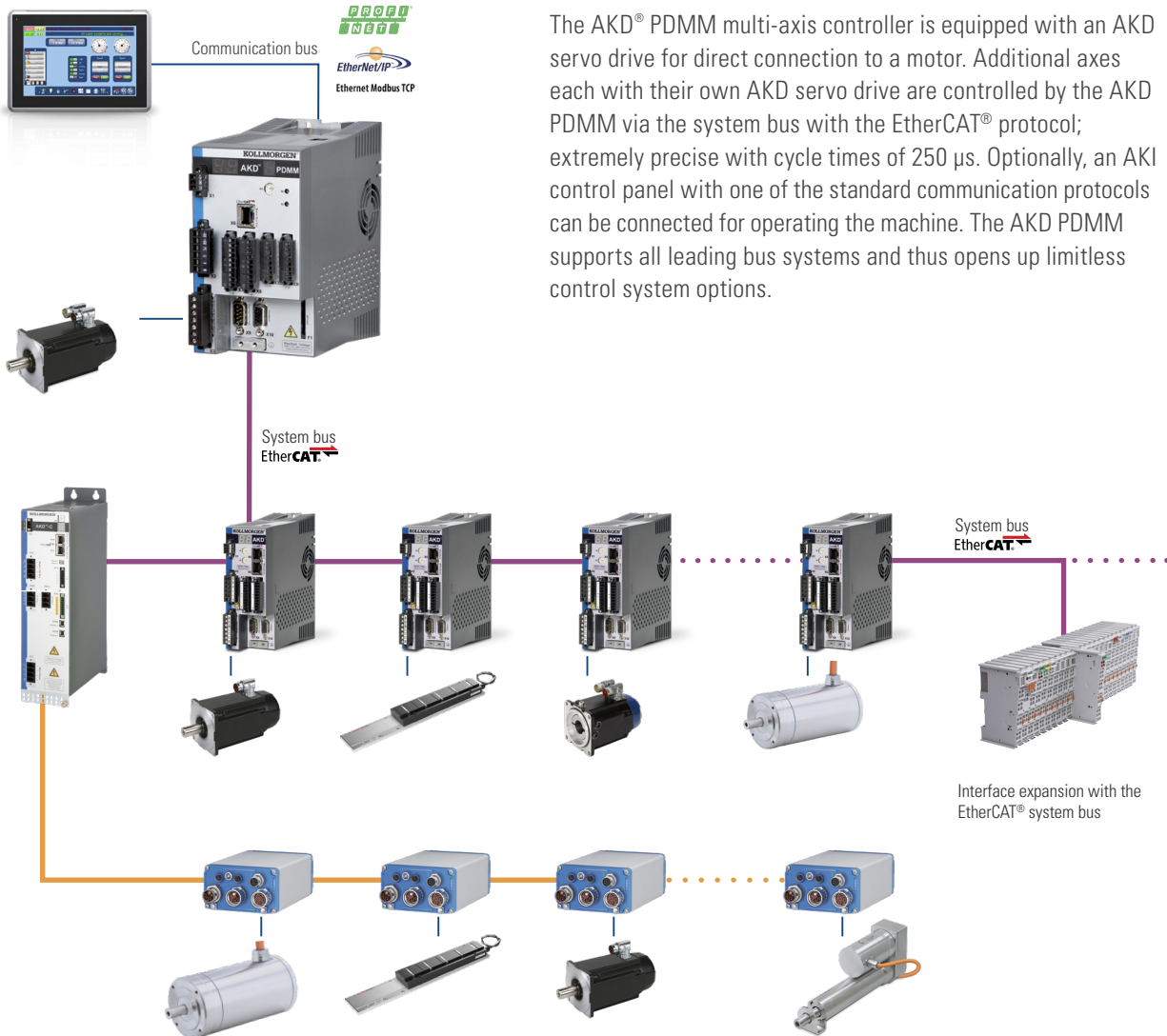

The AKD® PDMM multi-axis controller is equipped with an AKD servo drive for direct connection to a motor. Additional axes each with their own AKD servo drive are controlled by the AKD PDMM via the system bus with the EtherCAT® protocol; extremely precise with cycle times of 250 μ s. Optionally, an AKI control panel with one of the standard communication protocols can be connected for operating the machine. The AKD PDMM supports all leading bus systems and thus opens up limitless control system options.

Flexible single or multi-axis drive solutions in decentralized and central architectures with AKD-PDMM and the Kollmorgen Automation Suite™

Scalable Programmability

Kollmorgen delivers cutting-edge technology and performance with the AKD[®] servo drive and KAS controls platform. Whether your application requires a single axis or over 100 fully synchronized axes, Kollmorgen's intuitive software and tools scale to meet your needs. From simple analog torque control to the latest high-performance automation network, the AKD servo drive packs power and flexibility for virtually any application into one of the most compact footprints of any digital servo drive in the industry.

- Patented auto-tuning delivers optimized performance in seconds.
- 1.5MHz current loop and 16KHz velocity loops offers greater bandwidth and performance
Optimized performance in seconds
- Greater throughput and accuracy
- Easy-to-use Graphical User Interface (GUI) for faster commissioning and troubleshooting
- Flexible and scalable to meet any application

KOLLMORGEN AUTOMATION SUITE

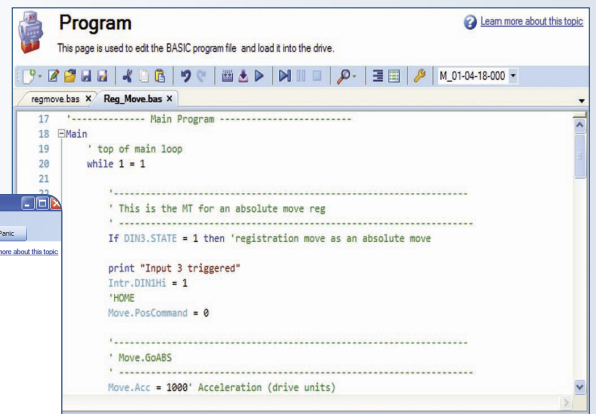
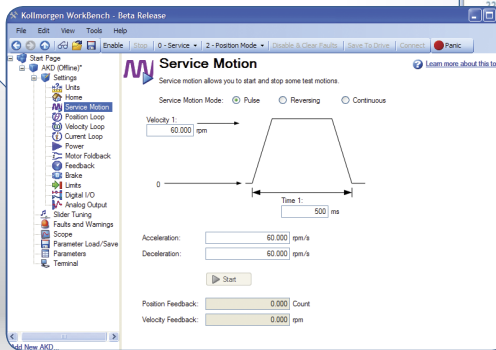
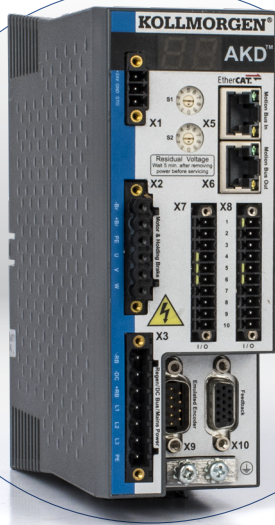

Motion Tasking ("P" Option)

- Adds simple point-and-click indexing to base drive
- Provides user with pre-programmed options
- Guides novice user through simplified steps to create indexing moves
- Network connectivity to EtherCAT[®], CANopen[®], Profinet[®] RT, Ethernet/IP[™], TCP/IP, SynqNet[®] and others
- MODBUS port for communication with HMI

BASIC Programmable 1.5 Axis Drive ("T" Option)

- Adds BASIC programmability to base AKD
- 4KHz programmable interrupt service routines
- Conditional statements, built-in math functions, user functions and subroutines
- Includes 2 high-speed digital inputs
- Same package size as base drive
- Expandable to 31 digital I/O and 4 analog I/O
- Optional integrated SD card for easy backup and drive cloning
- Includes electronic camming functionality

Basic Operation

Single-Axis

RANGE OF KOLLMORGEN AUTOMATION SUITE CAPABILITIES



KOLLMORGEN AUTOMATION SUITE

Programmable Drive Multi-Axis Master PDMM ("M" Option)

Seamlessly add additional axes and AKD PDMM serves as a high-performance multi-axis machine controller

- Scalable solution for use as a single-axis drive with integrated programmable automation controller
- Choose from all five IEC 61131-3 languages for soft PLC process programming
- Program motion using your choice of PLCopen for motion or our innovative Pipe Network™
- 4KHz PLC scan rate and EtherCAT® updates
- Complete line of HMI panels with integrated software to simplify GUI development
- Exclusive function blocks, such as "wait," enable your program to act as a scanning or sequential language
- On-board I/O includes 17 digital (with 2 high speed inputs) and 2 analog
- Connects to AKT™ network I/O for nearly unlimited expandability
- SD card for easy backup and system updates
- IoT-enabled integrated webserver for diagnostics and troubleshooting from any computer or mobile device
- Provide true synchronized-path control of up to 16 axes
- Reduce cabinet size and wiring requirements with a single, compact package
- Easily manage remote I/O and the I/O of all attached drives via EtherCAT®
- Use industry standard PLCopen for motion, or step up to Kollmorgen's Pipe Network™ to program sophisticated camming and gearing applications in a matter of minutes

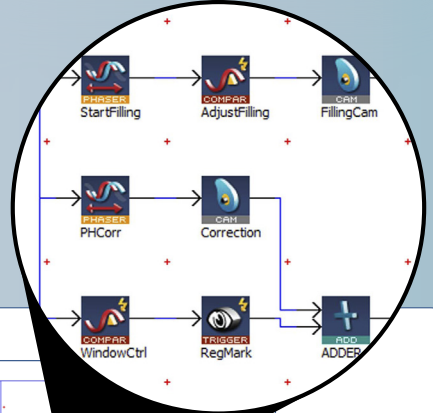

Pipe Network™ Kollmorgen Visual Motion Programming

- Accelerate development by programming tasks in hours that would otherwise take weeks
- Improved coding quality through visual programming and by using pre-built modules that have been thoroughly tested and optimized
- Easy knowledge transfer, replacing pages of complex code with easily understood graphical representations
- Available on PDMM controllers

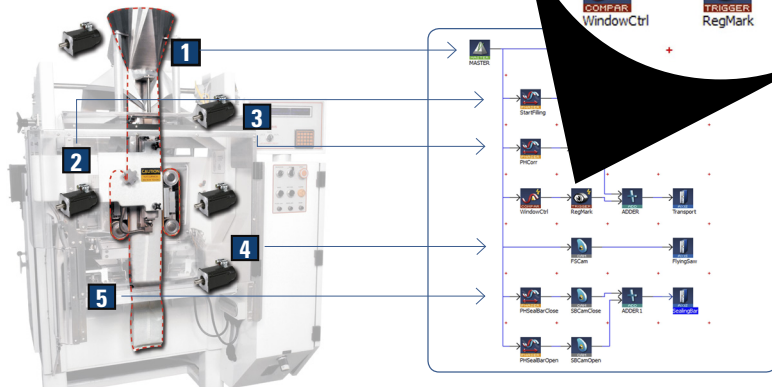

Pipe Network provides a one-to-one translation of a mechanical system into a logical world as shown in the Vertical Form Fill and Seal machine above. Click and build your motion program in minutes, or contact Kollmorgen for examples of common machine architectures to further accelerate your development.

Programming

Multi-Axis Programming

Development

A fully integrated development environment (IDE) provides the tools you need to develop everything from PLC and motion programs to HMI and device setup – all in one place. It's easier to learn and use, eliminates the need for multiple programs and data stores, and helps you bring a higher-quality machine to market faster.

Integrated Development Environment (IDE)

- Our fully integrated programming environment incorporates standard IEC61131-3 compliant tools.
- Use our network configurator and predefined user blocks to streamline development and ensure programming quality.

Our IDE offers two powerful programming methods and a complete set of tools for simulating, testing and optimizing motion.

Embedded Motion

- Choose PLCopen for motion if you already use this industry standard in your existing products, and want to continue using it within the Kollmorgen Automation Suite programming environment.



Embedded wiring diagrams and one-click IO variable mapping makes drive integration easy.

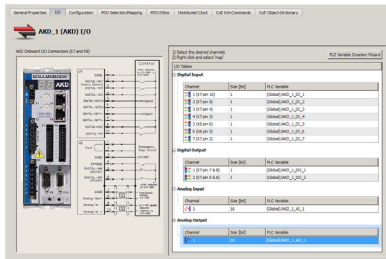

Integrated Tools

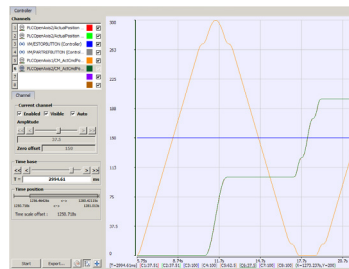

Scope motion parameters to fine-tune performance and synchronization, portrayed with up to eight channels and flexible mapping of variables.

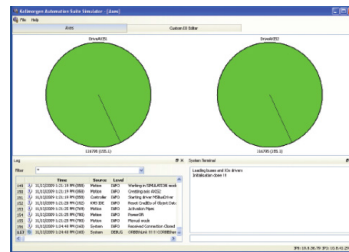

One-click motion simulation using virtual axes alongside real axes for quick development and implementation.

Pipe Network™ Kollmorgen Visual Motion Programming

- Choose Kollmorgen's exclusive Pipe Network™ for the quickest, easiest way to represent mechanical systems in software – using drag-and-drop tools to create an intuitive visual representation.

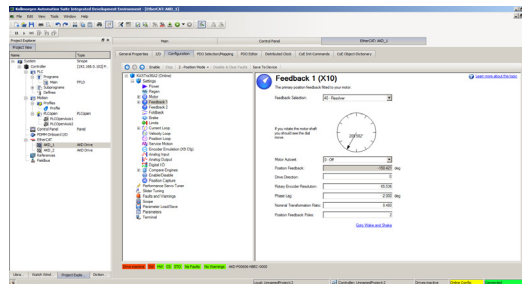
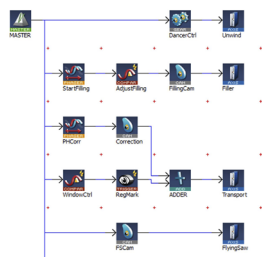

Complete motion system configuration from one location with embedded AKD Workbench allows configuration of all servo drives over EtherCat®.

Lifecycle

Kollmorgen is committed to helping you maximize the productivity and profitability of your machine across an extended lifecycle. Design and build today, with confidence for a full return on investment for years to come.

Continual Development Testing

Kollmorgen develops, tests, and continually validates all new products to ensure compatibility and performance, in the Kollmorgen ecosystem.

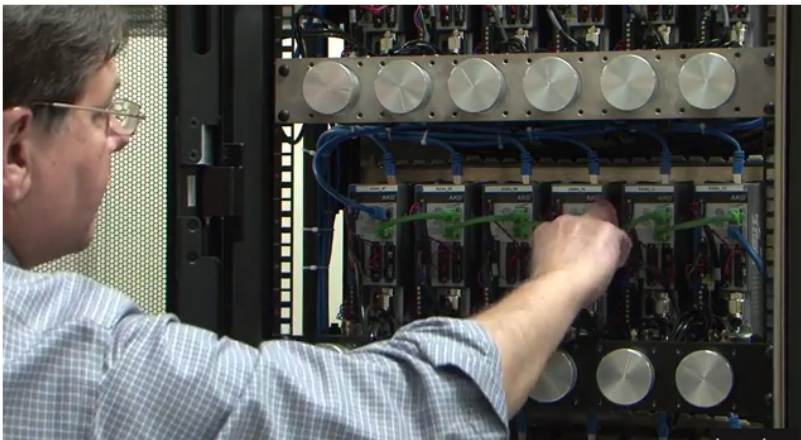

Maintenance Support Tools

Our tools give end-users the ability to remotely verify continuous operation and communicate issues effectively.

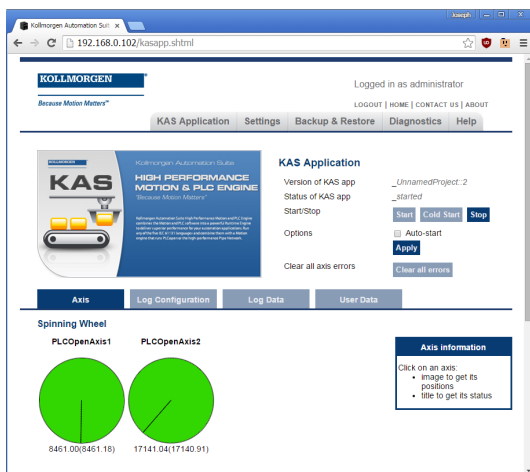

Built-in, mobile-ready webservice provides performance information with no software required

Software and Hardware Security

Password protection for source code and hardware connectivity provides security for both OEMs and end-users.



- ✓ Protect source code
- ✓ Protect network access

Software PLC

Easy-to-Use, Auto-Discover, Auto-Recognize, Auto-Configure, Scope, CAM, IEC 61131-3 PLC

- Kollmorgen Automation Suite™ offers a set of tools that is familiar to automation programs, but has enhancements like predefined motion blocks and visual diagnostics tools.

IEC 61131-3 Toolkit Features	• IEC-61131-3 engine	• PID temperature control block
	• Re-compile while running animated variables	• Debugger Tools with Watch window
	• Industry and application Specific Function Blocks	• 8-channel Real-Time Oscilloscope

- The environment for developing PLC programs has been created with an emphasis on speed. Recognize and configure motion control components to accelerate systems development. With auto-recognize and auto-configure features, testing efforts are reduced.
- Once an application or a function block has been created for a given application, the user can store this as a “user-defined function block” to promote reuse of tested software in subsequent projects to save time.
- Maintain your standards in corporate programming languages by using any of the IEC 61131-3 languages. In fact, enhance it further by mixing and matching languages to deliver the best solution for the application.

The screenshot displays the Kollmorgen Automation Suite interface with four programming language views:

- Sequential Function Chart (SFC):** Shows a state machine with four states (1-4) and transitions. State 1 is labeled (MLSTATUS_INIT), state 2 (MLSTATUS_RUNN), and state 3 (MLSTATUS...). State 4 is empty.
- Function Block Diagram (FBD):** Shows a logic diagram with function blocks and interconnections. Inputs include 'In1=FALSE', 'In2=TRUE', and 'In3=FALSE'. A timer block 'T1' is also visible.
- Ladder Diagram (LD):** Shows a network with a counter 'InstCTU' and various logic elements like 'Dwell2Done', 'PP_CyclesComplete or bStop_PP', and 'PP_RepeatCount'.
- Structured Text (ST):** Contains code for enabling and stopping motion.

```

On Machine_Enable TRUE DO //Enable Axis
  MLAxisPower( PipeNetwork.AXIS1 22 ,
  MLAxisPower( PipeNetwork.AXIS2 31 ,
END_DO;

IF FALSE Machine_Enable
  MLAxisPower( PipeNet
END_IF;

IF FALSE Machine_Enable
  MLAxisPower( PipeNet
END_IF;

//Stop Motion button pr
ON b_GC_StopMotion FALS
  MLMstRun( PipeNetwor
  b_GC_StartMotion TR
END_DO;
      
```
- Instruction List (IL):** Shows a list of instructions:

```

Begin_IL
  LD Input1 TRUE
  AND Input2 FALSE
  JMP Test
  //Store Result
  ST Output FALSE
  JMP End
Test:
  //Store Input1
  LD Input1 TRUE
  ST Output FALSE
END:
END_IL
      
```

All five IEC 61131-3 PLC languages are supported

- Kollmorgen Automation Suite's integrated development environment (IDE) allows the developer to create solutions without having to connect a single device by using the offline simulator. Start creating systems before the first hardware component is delivered. Simply configure your system network in "offline development" mode and change the status of the devices one-by-one when you actually connect them.

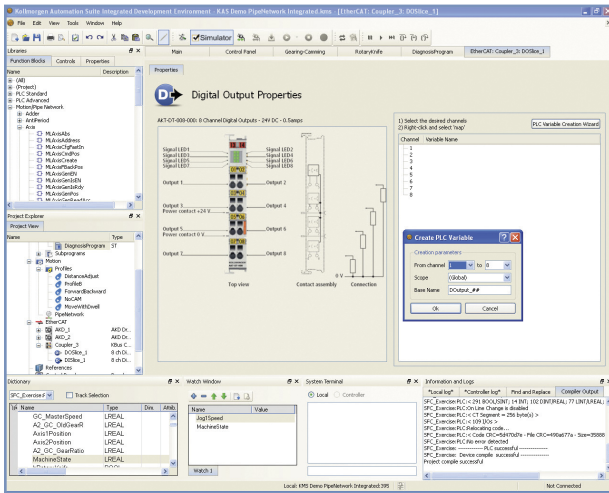

Automatic I/O variable creation with scope definitions
Adding bus couplers with I/Os onto a motion network topology

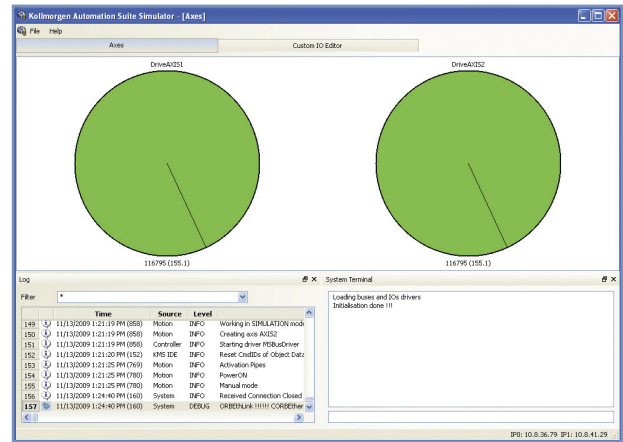

Simulator with PLC simulation and motion

- Standard debugging features like "step into", "step over", etc. are available to troubleshoot programs. In addition, debug your code using the softscilloscope and continuously plot up to 8 variables at network update rates – the display can also be configured to suit the scale that the developer desires.
- Our CAM editor lets you create complex CAM profiles using a graphical interface. When converting, it is also possible to import existing CAM profile points into the CAM editor to allow you to seamlessly reuse your existing profiles.
- CAM-on-the-Fly lets you change CAM profiles based on network inputs or changes in machine conditions.

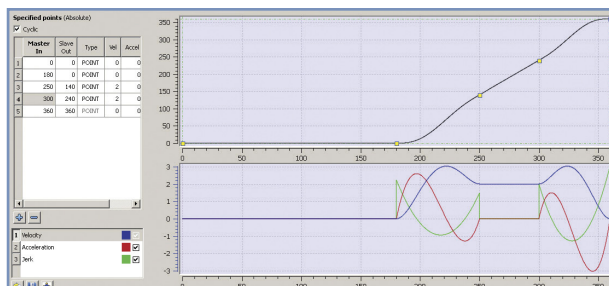

Graphical environment for creating CAMs

Motion Programming



Our motion control solutions are backed by Kollmorgen's vast experience solving application-specific problems for the many industries we serve. Kollmorgen Automation Suite™ offers several advantages that have helped our customers accelerate the development of more precise, high-performance motion. For example:

Superior machine synchronization, with motion-optimized runtime engine and deterministic EtherCAT® network:

- IEEE1588 distributed clock correction
- Hardware-based synchronization
- PLC code execution at EtherCAT® update rate, eliminating process delay
- Low hardware latency

Flexible profile generation, allowing problem-solving through multiple methods branching out of standard pre-packaged tools:

- Pre-loaded and user-defined motion blocks optimized for specific industries and applications
- Configurable through Pipe Network™ and PLCopen for motion

Motion Capabilities

- Absolute and incremental moves
- Jerk-limited moves (S-curve)
- CAM profiles (static or with “on-the-fly” profile changes)
- Gearing (EtherCAT® synchronized)
- Multiple high-speed registration methods (FPGA-based capture engine)
- Homing
- Tension control based motion
- Motion-based functional safety
- Superimposed moves
- Phase adjust
- Multi-axis interpolated motion

Program motion quickly and intuitively with our Pipe Network™ graphical programming language. Or choose the industry-standard PLCopen for motion to easily reuse your existing programming resources.

Pipe Network™ Visual Programming Environment

Our innovative Pipe Network™ programming environment provides a visual, drag-and-drop model of your machine's motion, including complex axis and cam relationships.

Program Tasks in Hours Instead of Weeks:

- Intuitive visual programming with a library of prebuilt modules.
- Easy knowledge transfer, replacing pages of complex code with easily understood graphical representations

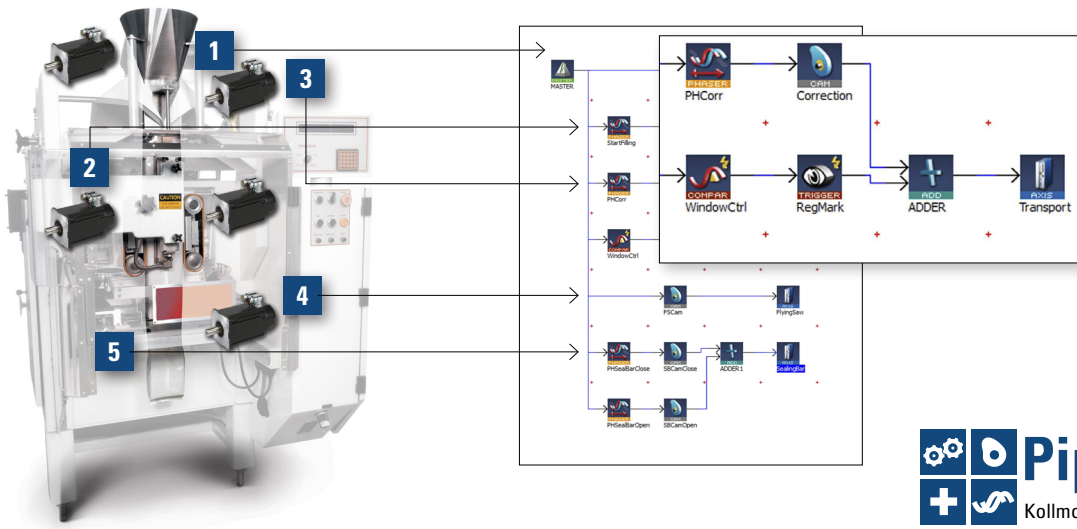

Pipe Network™ provides a one-to-one translation of mechanical systems into a logical world, so you can click and build your motion program in minutes – as shown in this example of a vertical form-fill-seal machine.



PLCopen for Motion

The Kollmorgen Automation Suite™ IDE incorporates PLCopen for motion, a widely accepted open industry standard.

In the example shown here, PLCopen for motion is used within the Kollmorgen Automation Suite IDE to precisely control axis position based on registration marks:

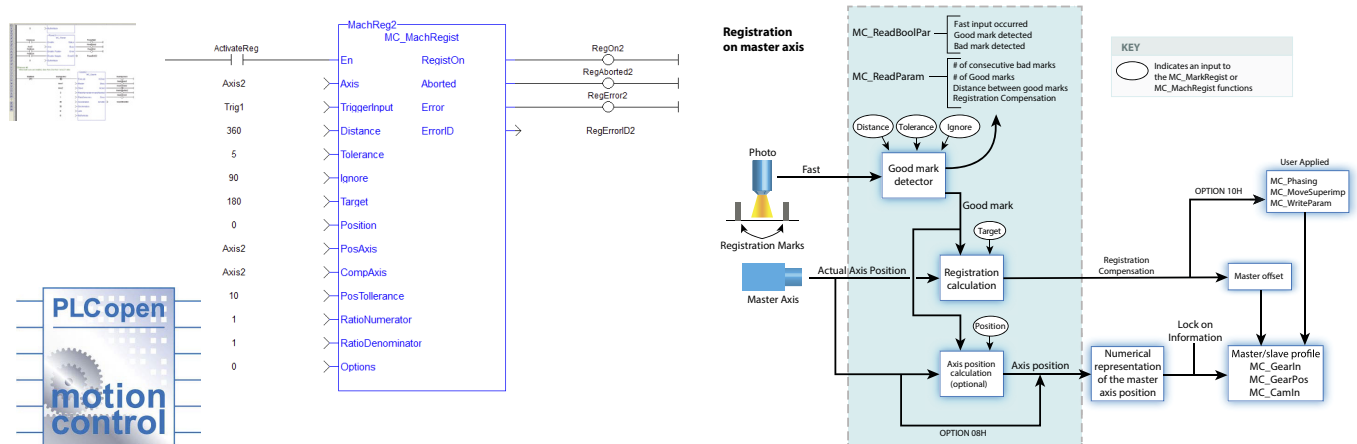

AKD[®] PDMM Drive-Resident Controller

Build Simpler and Better with Drive-Resident Machine and Motion Control

Extend your design options. Control as many as eight axes or more without the need for a PLC or PAC. Reduce cabinet space and wiring requirements. Program perfect machine and motion control for any project using a single, fully integrated programming environment. Build a better machine at a lower cost.

Our new addition to the AKD[®] drive family combines one servo axis, a master controller that supports multiple additional axes, and the full automation capability of Kollmorgen Automation Suite™—all in a single, compact package.

Welcome to the AKD[®] PDMM programmable drive, multi-axis master.

Performance Specifications

120/240 Vac 1- and 3-Phase	Continuous Current (Arms)	Peak Current (Arms)	H (mm/inches)	W (mm/inches)	D (mm/inches)
AKD-M00306-MCEC-0000	3	9	168 / 6.61	89 / 3.50	156 / 6.14
AKD-M00606-MCEC-0000	6	18	168 / 6.61	89 / 3.50	156 / 6.14
AKD-M01206-MCEC-0000	12	30	196 / 7.72	107 / 4.21	187 / 7.36
AKD-M02406-MCEC-0000	24	48	248 / 9.76	96 / 3.78	228 / 8.98

240/400/480 Vac 3-Phase	Continuous Current (Arms)	Peak Current (Arms)	H (mm/inches)	W (mm/inches)	D (mm/inches)
AKD-M00307-MCEC-0000	3	9	256 / 10.08	99 / 3.90	185 / 7.28
AKD-M00607-MCEC-0000	6	18	256 / 10.08	99 / 3.90	185 / 7.28
AKD-M01207-MCEC-0000	12	30	256 / 10.08	99 / 3.90	185 / 7.28
AKD-M02407-MCEC-0000	24	48	306 / 12.05	99 / 3.90	228 / 8.98
AKD-M04807-MCEC-0000	48	96	385 / 15.16	185 / 7.28	225 / 8.85

Features

- Kollmorgen Automation Suite™ provides fully integrated programming, testing, setup and commissioning
- Embedded web server utility simplifies service
- Control 32 axes or more* while reducing machine footprint
 - EtherCAT[®] multi-axis master motion controller integrated with a standard AKD[®] drive axis
 - Full IEC61131-3 soft PLC for machine control, with support for all 5 programming languages
 - Choice of PLCopen for motion or Pipe Network™ for programming motion control
 - 32 KB non-volatile memory stores machine data to eliminate scrap upon restart after power failure
 - SD Card slot simplifies backup and commissioning, with no PC required
 - On-board I/O includes 13 digital inputs, 4 digital outputs, 1 analog input, 1 analog output (expandable with AKT series of remote I/O)
- Works with Kollmorgen Visualization Builder for programming AKI human-machine interface panels

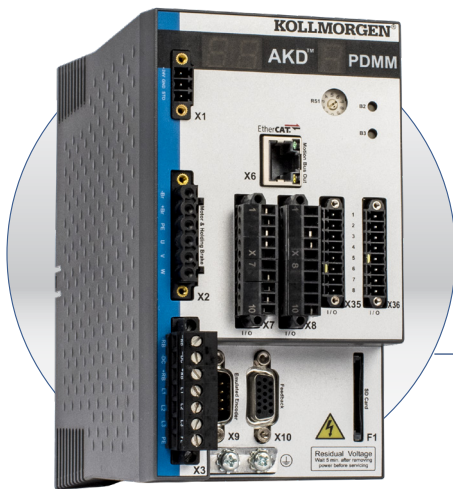

*Maximum axis count depends on motion/automation complexity and performance (8 axes nominal based on medium complexity at 4 kHz network update rate)

A Single, Scalable Development Suite

Kollmorgen Automation Suite™ simplifies and accelerates development through a unified system of software, hardware, and collaborative co-engineering. This scalable solution provides a fully integrated development environment for any application, whether you're programming a single axis of motion, a multi-axis AKD® PDMM system, or a PCMM-based system up to 64 axes or more. Kollmorgen Automation Suite has been proven to:

- Improve product throughput by up to 25% with industry-leading motion bandwidth
- Reduce scrap by up to 50% with world-class servo accuracy, seamless power-failure recovery and highly dynamic changeovers
- Increase precision for better quality, reduced waste and less downtime using EtherCAT®—the field bus with motion bus performance
- Enable more adaptable, sustainable and innovative machines that measurably improve marketability and profitability

A Single Family of Servo Drives

Kollmorgen AKD® servo drives deliver cutting-edge performance in a compact footprint. From basic torque-and-velocity applications, to indexing, to multi-axis programmable motion, these feature-rich drives offer:

- Plug-and-play compatibility with your servo motor
- All the advantages of Kollmorgen's breadth of motor platforms including AKM®, CDDR®, and other direct-drive technologies
- The fastest velocity and position loop updates
- Full-frequency auto-tuning for perfect motion across the performance spectrum
- Real-time feedback from a wide variety of devices

Our Best Drive and Automation Solution in a Single Package

The AKD PDMM programmable drive, multi-axis master combines our AKD drive platform with the full feature set of Kollmorgen Automation Suite in a single package—providing complete machine and motion control for up to eight axes or more.

You need only one development suite and one drive family for all your projects. And you can rely on one source for all the motion components and co-engineering expertise you need to build a better machine.

With AKD PDMM, the best in machine engineering has never been easier, faster or more cost-effective.



PCMM™ Stand-Alone Controller

Powerful Motion Controller in Small and Simple Package

The PCMM programmable motion controller delivers the same features as the drive-integrate AKD®-PDMM controller, but in a stand-alone package that offers flexibility when used with AKD®-N/C decentralized drives and for machines where the benefits of an integrated drive and controller are not required.

Ideal for OEMs that want to reduce cabinet space and machine complexity without sacrificing performance, the PCMM delivers full PLC functionality, a high-performance motion control and EtherCAT® master in one small package that easily installs in any electrical panel. Plus, programming is made easy using KAS IDE which includes PipeNetwork™ visual programming, one-click simulation, and integrated configuration and diagnostic tools simplify machine development and help you get to market faster.

Part Number	Processor
AKC-PCM-MC-080-00N-00-000	800 MHz Standard Multi-axis Controller
AKC-PCM-M1-120-00N-00-000	1.2 GHz High Performance Multi-axis Controller

General Features and Specifications

Processor	Available with 1.2GHz or 800MHz CPU
Internal Memory	64 MB Flash memory for program storage
External Memory	Removable SD card (not included)
Input Power	24 Vdc @ 1.25 A
Operating Temperature	0 °C - 40 °C
Sealing	IP20
Local I/O	6 digital inputs, 2 digital outputs
Motion Network	EtherCAT®, max 4kHz update rate
PLC Programming	IEC-61131-3, support for all 5 languages
Motion Programming	PLCopen or PipeNetwork®
HMI Programming	KVB programming for AKI panels
Dimensions	174mm (H) x 46.6mm (W) x 111.5mm (D)
Certifications	CE / UL (planned)



I/O

PCMM™ Hardware Features

- Up to 1.2GHz CPU meets the performance requirements for a broad range of machines
- Control 1 to 30 or more axes with a single controller
- 100BaseT connection supporting TCP/IP, MODBUS®, EthernetIP®, Profinet® to host PLC, computer, or network to easily interface with most manufacturing systems
- Cycle times as low as 250 µs
- Alphanumeric display for fast diagnostics and system troubleshooting
- Removable SD memory card for simple backup/restore and file storage
- On-board digital I/O with support for expansion I/O via EtherCAT®
- Compact size reduces cabinet space and cost

PCMM™ Software Features

- IEC 61131-3 programmable automation and motion controller
- EtherCAT® master for high-performance motion and device synchronization
- PipeNetwork™ motion engine for visual programming
- Embedded RTOS for guaranteed performance and stability
- Integrated webserver for remote diagnostics and status checking
- Ideal design for modular machines and flexible manufacturing systems

PCMM™ System Integration

- Seamless integration with Kollmorgen's AKD® servo drives, AKM® rotary servo motors, AKI HMIs, and AKT fieldbus I/O modules for complete automation solution
- Network communication via OPC, MODBUS®, TCP/IP, UDP, and common fieldbus for fast integration into your machine or factory
- Intuitive EtherCAT® configuration tools built into KAS IDE simplifies network configuration
- Integrated Kollmorgen Workbench for rapid servo tuning and machine optimization

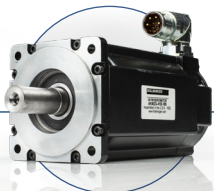
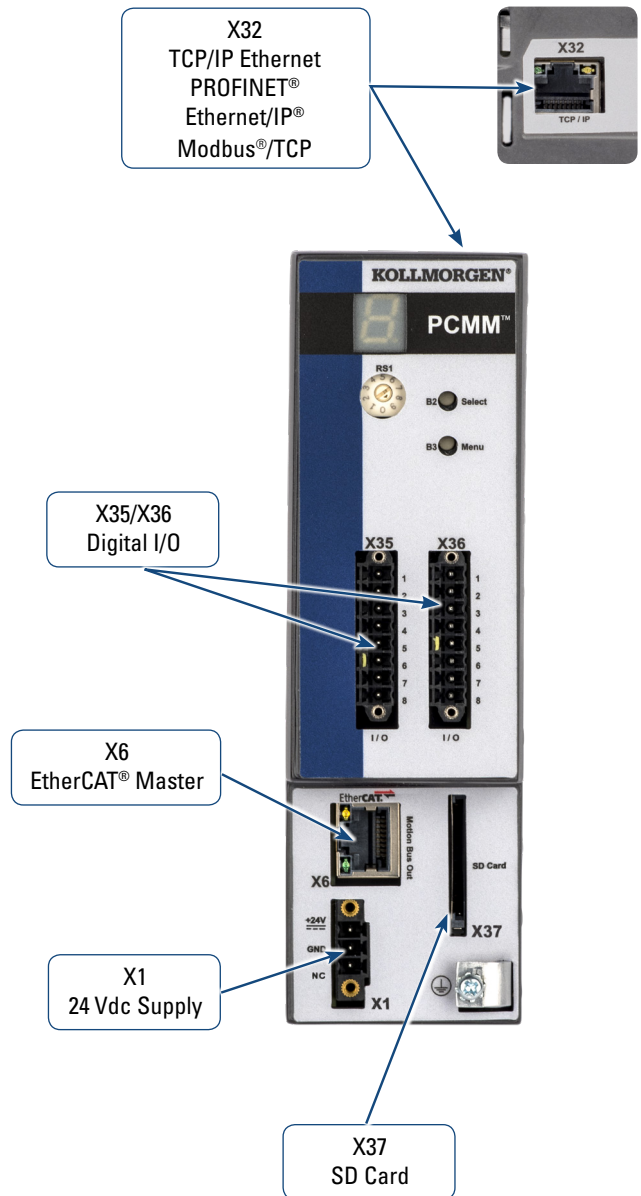

AKM® 2G Servo Motor



AKD®-N Servo Drive



AKD® Servo Drive



HMI

Real-time Motion Bus



EtherCAT® Real-time Bus for Motion and I/O Connectivity

- Auto-recognition of Kollmorgen Automation Suite-compatible components
- Guaranteed real-time update cycle down to 250 microseconds.
- Supported by 2000+ member companies
- Standard Ethernet cabling = lower implementation cost
- Interoperability with other buses
- Wide availability of devices

EtherCAT® Performance Overview

Process Data	Update Time
256 distributed digital I/O	11 μ s = 0.01 ms
1000 distributed digital I/O	30 μ s
200 analog I/O (16 bit)	50 μ s – 20 kHz
100 Servo Axis, with 8 Bytes input and output data each	100 μ s
1 Fieldbus Master-Gateway (1486 Bytes Input and 1486 Bytes Output Data)	150 μ s

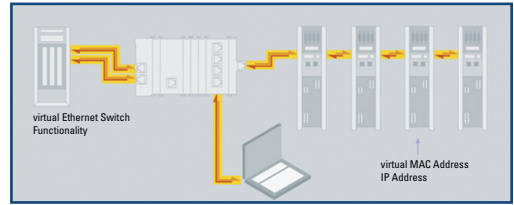

Transparent for all Ethernet protocols

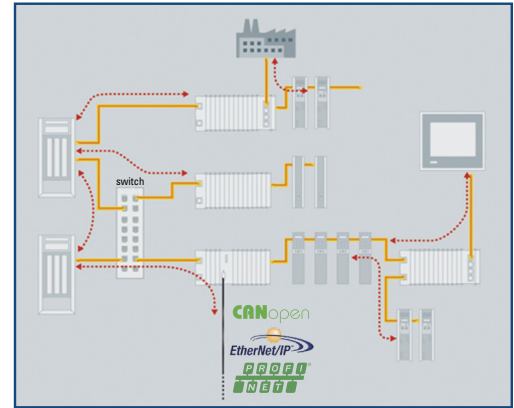

Versatile network architecture

Kollmorgen EtherCAT® Bus Coupler

See page 26 for models and configurations

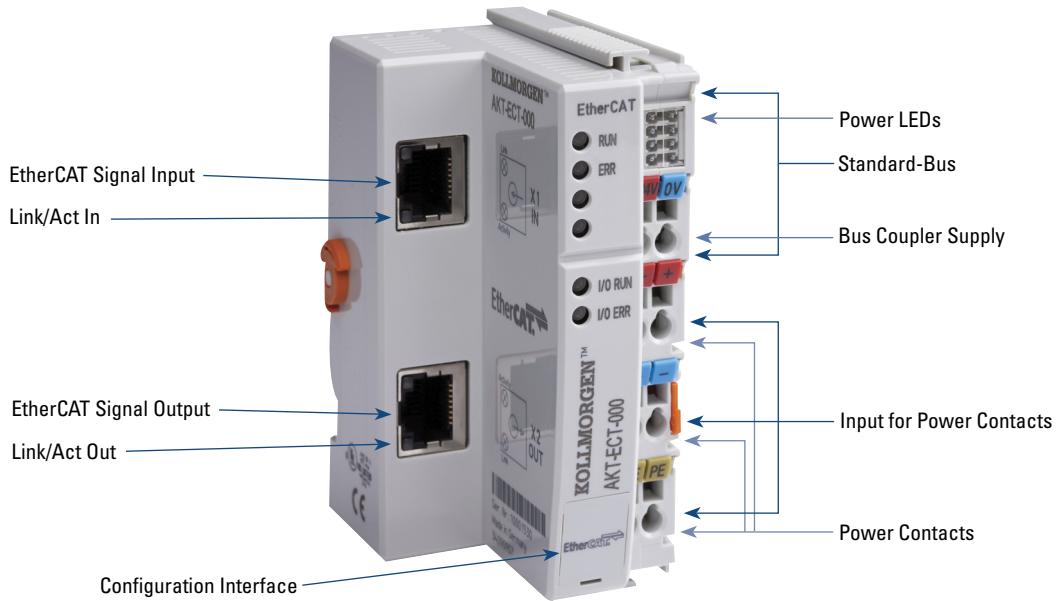

Human Machine Interface (HMI)

AKI2G-CDA Series



Specifications	5 inch AKI2G-CDA-MOD-05T-000	7 inch AKI2G-CDA-MOD-07T-000
General Description		
Part number	630005105	630005205
Certifications		
General	CE, FCC, KCC	
Marine	-	
UL	UL 61010-2-201	
Mechanical		
Mechanical size	170 × 107 × 49 mm	196 × 146 × 52 mm
Touch type	Resistive	
Cut-out size	161 × 93 mm	186 × 136 mm
Weight	0.5 kg	0.7 kg
Housing material	Plastic (PC+ABS), Gray	
Power		
Input voltage	24 V DC (18 to 32 VDC) CE: The power supply must conform with the requirements according to IEC 60950 and IEC 61558-2-4. UL and cUL: The power supply must conform with the requirements for class II power supplies.	
Power consumption	6W	9.6W
Input fuse	Internal DC fuse	
System		
CPU	ARM9 400 MHz	
RAM	128 MB	
FLASH	256 MB, 200 MB free for application storage	
Display		
Size diagonal	5" diagonal	7" diagonal
Resolution	800 × 480 pixels	
Backlight	LED Backlight	
Backlight life time	20 000 hours	
Backlight brightness	300 cd/m ²	400 cd/m ²
Backlight dimming	Industrial Dimming	
Display type	TFT-LCD with LED backlight	
Display pixel error	Class I (ISO9241-307)	
Communication Serial		
Number of serial ports	2 Port 9pin DSUB	
Serial port 1	RS 232 (RTS/CTS)	
Serial port 2	RS422/485	
Serial port 3	RS 232	
Serial port 4	RS 485	
Ethernet Communication		
Number of ethernet ports	1	
Ethernet port 1	1 × 10/100 Base-T (shielded RJ45)	
Ethernet port 2	-	
Expansion interface		
Expansion port	No	
SD card	No	
USB	1 × USB 2.0 500mA	
Environmental		
Operating temperature	-10°C to +50°C	
Storage temperature	-20° to +60°C	
Shock	15g, half-sine, 11ms according to IEC60068-2-27	
Vibration	1g, according to IEC 60068-2-6, Test Fc	
Sealing front	IP65	
Sealing back	IP20	
Humidity	5% – 85% non-condensed	

Human Machine Interface (HMI)

AKI2G-CDB Series



Specifications	7 inch AKI2G-CDB-MOD-07T-000	12 inch AKI2G-CDB-MOD-12T-000
General Description		
Part number	630000205	640000205
Certifications		
General	CE, FCC, KCC	
Marine	DNV, KR, GL, LR, ABS, CCS	
UL	UL 61010-2-201	
Mechanical		
Mechanical size	204 × 143 × 50 mm	340 × 242 × 57 mm
Touch type	Resistive	
Cut-out size	189 × 128mm	324 × 226mm
Weight	0.8 kg	2.6 kg
Housing material	Powder-coated aluminum, Gray	
Power		
Input voltage	24 V DC (18 to 32 VDC) CE: The power supply must conform with the requirements according to IEC 60950 and IEC 61558-2-4. UL and cUL: The power supply must conform with the requirements for class II power supplies.	
Power consumption	14.4W	28.8W
Input fuse	Internal DC fuse	
System		
CPU	i.MX6Solo Single Cortex-A9 1.0GHz 512kBL2cache	i.MX6DualLite, Dual Cortex-A9 1.0GHz 512kBL2cache
RAM	512 MB	1 GB
FLASH	2GB SSD(eMMC), 1.5GB free for application storage	
Display		
Size diagonal	7" diagonal	12.1" diagonal
Resolution	800 × 480 pixels	
Backlight	LED Backlight	
Backlight life time	20 000 hours	50 000 hours
Backlight brightness	350 cd/m ²	400 cd/m ²
Backlight dimming	Industrial Dimming	
Display type	TFT-LCD with LED backlight	
Display pixel error	Class I (ISO9241-307)	
Communication Serial		
Number of serial ports	1 Port 9pin DSUB	
Serial port 1	RS 232 (RTS/CTS)	
Serial port 2	RS422/485	
Serial port 3	RS485 (only if COM 2 is RS485)	
Ethernet Communication		
Number of ethernet ports	1	2
Ethernet port 1	1 × 10/100 Base-T (shielded RJ45)	
Ethernet port 2	–	1 × 10/100 Base-T (shielded RJ45)
Expansion interface		
Expansion port	Yes, ciX expansion module	
SD card	SD and SDHC	
USB	1 × USB 2.0 500mA	2 × USB 2.0 500mA
Environmental		
Operating temperature	-10°C to +60°C	
Storage temperature	-20° to +70°C	
Shock	15g, half-sine, 11ms according to IEC60068-2-27	
Vibration	1g, according to IEC 60068-2-6, Test Fc	
Sealing front	IP65, NEMA 4X/12 and UL Type 4X/12	
Sealing back	IP20	
Humidity	5% – 85% non-condensed	

I/O Terminals

Advanced Kollmorgen Terminal (AKT)

The Kollmorgen Automation Suite™ includes an array of I/O options for applications that need more I/O than can be provided by the onboard I/O of the drives or for applications that need specialized functionality such as thermocouple management through I/O. The DIN rail mount IP20 terminals simply slide together and connect to the system's EtherCAT® bus where they are auto-recognized for easy configuration.



Typical Bus Coupler



EtherCAT® bus coupler

Typical I/O Terminal



Front wiring view

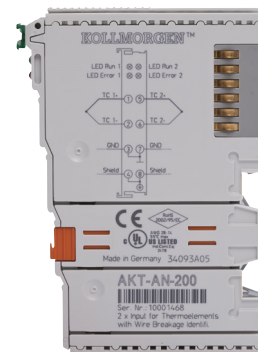

Side label view

Available Motion Bus Coupler Model

AKT-ECT-000-000	EtherCAT® Bus Coupler
-----------------	-----------------------

Available Analog Input Terminal Models

AKT-AN-410-000	4 channel analog input module, 0-10 Vdc
AKT-AN-420-000	4 channel analog input module, 0-20 ma
AKT-AN-810-000	8 channel analog input module, 0-10 Vdc
AKT-AN-820-000	8 channel analog input module, 0-20 ma
AKT-AN-200-000	2 channel thermocouple input module
AKT-AN-400-000	4 channel thermocouple input module

Available Analog Output Terminal Models

AKT-AT-220-000	2 channel analog output module, 0-20 ma
AKT-AT-410-000	4 channel analog output module, 0-10 Vdc
AKT-AT-420-000	4 channel analog output module, 0-20 ma
AKT-AT-810-000	8 channel analog output module, 0-10 Vdc
AKT-AT-820-000	8 channel analog output module, 0-20 ma

Available Digital Output Terminal Models

AKT-DT-004-000	4 channel digital output module, 0.5A
AKT-DT-008-000	8 channel digital output module, 0.5A
AKT-DT-2RT-000	2 channel relay output module, 2.0A, N/O

Available Digital Input Terminal Models

AKT-DN-004-000	4 channel digital input module, 3ms
AKT-DNH-004-000	4 channel digital input module, .2ms
AKT-DN-008-000	8 channel digital input module, 3ms
AKT-DNH-008-000	8 channel digital input module, .2ms

Available Specialty Terminal Models

AKT-EM-000-000	End module
AKT-IM-000-000	Isolation module
AKT-PS-024-000	Bus feed terminal, 24 Vdc
AKT-PSF-024-000	Bus feed terminal, 24 Vdc, fused

Available Field Bus Coupler Models

AKT-PRB-000-000	Profibus Bus Coupler
AKT-ENP-000-000	Ethernet/IP Bus Coupler

Stepper Driver

AKT-SM-L15-000	Stepper Module, 24 Vdc, 1.5 A
AKT-SM-L50-000	Stepper Module, 50 Vdc, 5 A

Kollmorgen Developer Network

Kollmorgen Developer Network (KDN) is the central location for engineers to quickly get support on all Kollmorgen products, interact with and learn from the larger Kollmorgen user community, and receive expert instruction from Kollmorgen Applications Engineers and staff.

The screenshot shows the Kollmorgen Developer Network (KDN) website. The browser address bar displays 'https://kdn.kollmorgen.com'. The website header includes the Kollmorgen logo with the tagline 'Because Motion Matters™', navigation icons for Home, Knowledge Base, Community, and Downloads, and a login section with fields for E-mail and Password, and links for 'Forgot password?', 'Register', and 'Log in'. The main content area features a large blue banner with the text 'Kollmorgen Developer Network' and a search bar with the placeholder 'Enter your keywords'. To the right of the banner is a promotional message: 'Spend less time troubleshooting and more time developing. We created the Kollmorgen Developer Network so you can focus on what matters most: Building awesome machines.' Below the banner, the page is organized into several sections: 'Getting Started' with tips for new users; 'Latest Posts' featuring two articles by 'cwtrop' and 'jcoleman02' about drive opmodes and KVB sample projects; 'Resources' with links to various help pages in multiple languages and online tools; and 'Featured Content' with links to specific technical articles like 'AKD Backup FPGA Notice' and 'Connecting a PDMM to a vision system via Ethernet/IP'.

Ask a Question

Ask a question, or search and respond to existing questions. Provide an answer, or vote on the best answer. Leverage the global scope of Kollmorgen to get up to speed quickly.

Start a Discussion

Want to share a best practice, get feedback, or understand how others are solving similar problems? Start a new discussion, or join an active one, to share in the collaborative experience and knowledge of Kollmorgen product developers.

Propose a Feature

Have an idea for a new product, or feature? Submit it here. Customers speak and we listen. We know one size does not fit all. Our product is flexible, but sometimes differentiation requires a collaborative approach.

Latest Downloads

Keep up with our continually improving product, with access to the latest downloads.

Custom Capabilities

Kollmorgen offers 5-day lead-time on nearly 1,000,000 commercial off-the-shelf (COTS) products, all with best-in-class performance and quality.

When COTS is not quite the best way to realize a totally optimized system, Kollmorgen can offer co-engineered solutions to meet your most difficult challenges and advance your competitive position. Drawing on a wealth of knowledge and expertise, our engineering support team will work alongside you to build a solution that differentiates your machine and improves your bottom line.

Here are just few examples of how Kollmorgen delivers real value to companies like yours:

What You Need	Why Motion Matters	Kollmorgen Co-Engineering Results
30% Increase in Throughput	<ul style="list-style-type: none"> • Low inertia servo motors • High bandwidth servo loops • Simple, accurate, graphical programming tools 	Using the Kollmorgen Automation Suite™ graphical camming design tool, Pipe Network™ and low-inertia AKM® servo motors, a major supplier of diabetic test labs increased throughput by more than 30% while improving accuracy and reducing scrap.
50% Increase in Accuracy and Quality	<ul style="list-style-type: none"> • Low cogging frameless servo motor • Advanced observers and bi-quad filters • Fast control loop update rates (.67µs) 	Using our AKD® servo drive, a next-generation CT scanning manufacturer achieved more than 50% improvement in velocity ripple to produce the most accurate and detailed medical images possible while overcoming an extremely high moment of inertia.
25% Increase in Reliability (Overall Equipment Effectiveness)	<ul style="list-style-type: none"> • Innovative Cartridge Direct Drive Rotary® DDR motor • Eliminating parts on the machine • No additional wearing components 	Using Kollmorgen's award-winning Cartridge DDR® servo motor technology, we eliminated more than 60 parts in a die-cutting machine and increased the OEE by 25% and throughput by 20%.
50% Reduction in Waste	<ul style="list-style-type: none"> • Superior motor/drive system bandwidth • DDR technology: <ul style="list-style-type: none"> – eliminates gearbox – 20X more accurate than geared solution 	We helped a manufacturer of pharmaceutical packaging machines incorporate Housed DDR motors to increase the throughput by 35% and reduce scrap by more than 50% through more accurate alignment of the capsules.

Optimized Solutions Process

Comprehensive design, manufacture and test capabilities ensure the end product meets the customer performance specifications and quality requirements. Our skilled engineering team works directly with each customer throughout the process, quickly taking the prototype to full production.

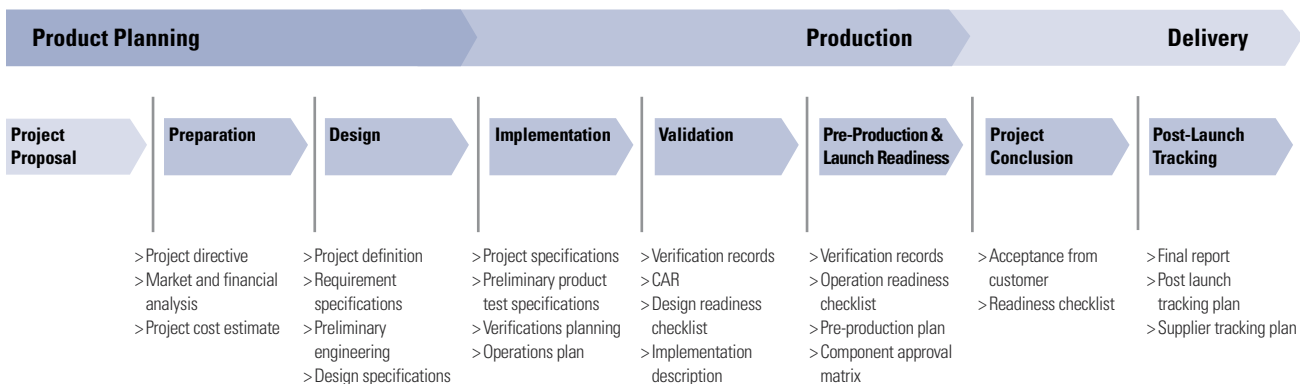

MOTIONEERING® Online

MOTIONEERING® Online – Kollmorgen has revamped, modernized and put online one of the most respected applications sizing programs of the last 20 years. You now can access this application sizing and selection tool wherever you have access to the internet. MOTIONEERING Online is just a start of a series of releases that will empower you to optimize solutions for your toughest applications. Sizing frameless motors and drive systems has never been easier. Using a mechanism project concept for collecting and saving multiple axes of load information, MOTIONEERING® Online can automatically calculate application results and compare against a catalog of systems - recommending the most optimized set of Kollmorgen system solutions available.

Versatile units-of-measure selection options for mechanism and motion profile data-entry, with the ability to convert data into other available units, makes this a convenient international tool. A user-friendly Help file teaches program functions and algorithms used to provide results.

Mechanism Projects

- Direct drive entry, lead screw, conveyor
- Rack and pinion, nip rolls
- Direct Drive Rotary
- Electric Cylinder
- Direct data entry

Desired Safety Margins

Continuous Torque Margin 10%
Peak Torque Margin 10%
Maximum Speed Margin 10%

Result Legend

- Meets or exceeds all criteria
- Meets physical requirements but fails to meet one or more safety margins
- Meets performance requirements except for inertia ratio
- Meets requirements except amplifier time constant
- Fails to meet one or more performance requirements

System-Motor/Amplifier	Continuous Torque Margin (%)	Peak Torque Margin (%)	Maximum Speed Margin (%)	Power Margin (%)	Inertia Ratio	
AKM425F-AND-00056 (240 V)	37	105	11	104	31.737	Select
AKM425C-AND-00077 (480 V)	32	12	11	101	31.737	Select
BH-124-B-570302 (480 V)	49	173	4	176	14.870	Select
AKM425F-AND-00036 (240 V)	1	34	11	97	42.578	Select
MH-227-B-570302 (480 V)	84	119	4	245	2.885	Select
MH-125-B-570302 (480 V)	37	143	4	154	2.028	Select
BH-125-B-570302 (480 V)	111	180	4	283	8.961	Select
AKM425F-AND-00056 (120 V)	2	1	11	81	42.578	Select
AKM425F-AND-00069 (120 V)	37	100	13	89	31.737	Select
AKM425F-AND-00066 (120 V)	61	100	134	40	26.891	Select
AKM412F-AND-00104 (120 V)	42	100	41	2	20.773	Select

Solution Set Search Screen

- Color-coded indication of system's ability to meet application requirements
- Review system components specifications
- Save, print, or create a pdf application report
- Evaluate system performance curve with application points

MOTIONEERING® Online Features:

- Inertia Calculator - lets you build up inertia based on odd shapes by additive or subtractive methods
- Custom Motion Profile - easy to add entire segments or copy segments to repeat
- Environmental Factor - takes into account your ambient temperature
- Project by Project Units - You can tailor your units on a project by project basis, or use the global units settings

MOTIONEERING Online Supported Browsers

- IE, Chrome, Firefox, Safari



www.kollmorgen.com/motioneering

Because Motion Matters

About Kollmorgen

Since its founding in 1916, Kollmorgen's innovative solutions have brought big ideas to life, kept the world safer, and improved peoples' lives. Today, its world-class knowledge of motion systems and components, industry-leading quality, and deep expertise in linking and integrating standard and custom products continually delivers breakthrough motion solutions that are unmatched in performance, reliability, and ease-of-use. This gives machine builders around the world an irrefutable marketplace advantage and provides their customers with ultimate peace-of-mind.

For assistance with your application needs
in North America, contact us at: **540-633-3545**,
support@kollmorgen.com or visit
www.kollmorgen.com for a global contact list.



KOLLMORGEN®

Because Motion Matters™

Kollmorgen
203A West Rock Road
Radford, VA 24141 USA
Phone: 1-540-633-3545
Fax: 1-540-639-4162

Kollmorgen Europe GmbH
Pempelfurtstraße 1
40880 Ratingen
Germany
Phone: +49 (0) 2102 9394 0
Fax: +49 (0) 2102 9394 3155

Kollmorgen Asia
Floor 4, Building 9, No. 518,
North Fuquan Road, Changning District,
Shanghai 200335, China
Phone: + 86 400 661 2802

Kollmorgen Aerospace and Defense
501 West Main Street
Radford, VA 24141 USA
Phone: 1-540-731-5668
Fax: 1-540-731-5679