

Screw Driven automation tables

Precise multi-axis positioning systems play an integral part in today's semiconductor, computer peripheral, solar power, flat panel, life sciences, lab automation, biomedical and electronics industries. The demands for tighter specifications, improved throughput and consistent quality have become increasingly stringent. Because of the complexity associated with these systems, many manufacturers insist on a single source supplier to eliminate multiple vendor design incompatibilities and delivery conflicts. With over forty years' experience as a global leader in the development of products and technology, Parker provides the most advanced, easy to integrate high-precision electromechanical systems.

Contents

30-33	Overview
34-63	400XR Series Precision Linear Positioners
64-69	XRS Cartesian Systems
70-79	402/403XE Series Positioners
80-89	404XE Series Positioners
90-111	HD Series Industrial Linear Positioners
112-127	Ultra Series Precision Stages
128-133	100CT & 800CT Series Tables
134-137	200RT Series Rotary Tables
138-141	R Series Worm Drive Rotary Tables
142-145	ZP200 Series Vertical Lift "Wedge" Table
146-150	Additional Products

404XE Series Positioners (95 mm wide profile)

Features

- Economy Grade Positioning
- 100% Duty Cycle
- High Strength Design
- Easy Multi-Axis Mounting
- Locating Dowel Holes



Reliable and Cost Effective Positioning

The 404XE positioners combine versatility with rugged construction in a compact motion platform that is ideal for 24/7 process automation. A high efficiency ballscrew drive, recirculating square rail bearings and high strength aluminum body are the result of innovative engineering that has reduced costs while improving performance.

Unmatched Options and Features

A vast assortment of “designer friendly” options and features simplify the engineering challenges often confronted with “base model” positioning devices. Features like precision dowel holes, linear feedback, sensor packs, parallel motor mounting, brakes, and cleanroom preparation simplify and speed your machine design process.



Multi-Axis Systems

XY and XYZ systems are easily configured and pinned so that factory orthogonality can be reproduced in the field. Motors and cable management systems connect to the XE tables in a straightforward and simple manner.



Technology Evolution

The XE is direct mounting compatible with our precision series XR ballscrew tables and our LXR linear motor tables. It is possible to mix-and-match various levels of technology on a per axis basis allowing the most cost effective optimized application solutions.





Common Specifications

Bidirectional Repeatability	
T01 to T11 models	±20 micron
T12 to T15 models	±30 micron
Duty Cycle	100%
Max Acceleration⁽¹⁾	20 m/sec ² (773 in/sec ²)
Normal Load Capacity⁽²⁾	
NL (short carriage)	61.3 kgf (135 lbs)
VL (long carriage)	122.6 kgf (270 lbs)
Axial load capacity⁽²⁾	
5 mm lead ballscrew	60 kgf (132 lbs)
10 mm lead ballscrew	70 kgf (154 lbs)
20 mm lead ballscrew	70 kgf (154 lbs)
Drive Screw Efficiency	90%
Max Break-Away Torque	0.25 Nm (35in-oz)
Max Running Torque (rated @ 2 RPS)	0.21 Nm (30in-oz)
Linear Bearing – Coefficient of Friction	0.01
Ball screw Diameter	
5 & 10 mm lead	16 mm
20 mm lead	15 mm
Carriage Weight	
NL (short carriage)	0.215 kg (0.47 lbs)
VL (long carriage)	0.495 kg (1.09 lbs)

(1) Applies to units with VL carriage

(2) Refer to life/load charts.

Travel Dependent Characteristics

Code	Travel (mm)		Positional Accuracy ^{(3) (4)} (µm)	Input Inertia NL Carriage Units (10 ⁻⁵ kg-m ²)			Input Inertia VL Carriage Units (10 ⁻⁵ kg-m ²)			Max. Screw Speed (RPS)	Max. Velocity (meters/sec.)			Total Table Weight (kg)	
	NL	VL		5 mm	10 mm	20 mm	5 mm	10 mm	20 mm		5 mm	10 mm	20 mm	NL	VL
T01	25	–	42	.81	–	–	–	–	–	72	0.36	0.73	1.50	1.42	1.70
T02	50	–	50	.94	.98	–	–	–	–	72	0.36	0.73	1.50	1.61	1.89
T03	100	33	58	1.19	1.23	1.12	1.21	1.30	1.4	72	0.36	0.73	1.50	1.95	2.23
T04	150	83	66	1.44	1.48	1.32	1.46	1.55	1.6	72	0.36	0.73	1.50	2.35	2.63
T05	200	133	74	1.69	1.73	1.51	1.71	1.80	1.79	72	0.36	0.73	1.50	2.59	2.87
T06	250	183	82	1.94	1.99	1.70	1.96	2.06	1.99	72	0.36	0.73	1.50	2.97	3.25
T07	300	233	90	2.20	2.24	1.90	2.21	2.31	2.18	72	0.36	0.73	1.50	3.34	3.62
T08	350	283	98	2.45	2.49	2.09	2.47	2.56	2.37	72	0.36	0.73	1.50	3.50	3.78
T09	400	333	106	2.70	2.74	2.29	2.72	2.81	2.57	72	0.36	0.73	1.50	3.83	4.11
T10	450	383	114	2.95	2.99	2.48	2.97	3.07	2.76	72	0.36	0.73	1.50	4.09	4.37
T11	500	433	122	3.21	3.25	2.67	3.22	3.32	2.96	72	0.36	0.73	1.50	4.22	4.50
T12	550	483	130	3.46	3.50	2.87	3.48	3.57	3.15	72	0.36	0.73	1.50	4.55	4.83
T13	600	533	138	3.71	3.75	3.06	3.73	3.82	3.34	69	0.34	0.68	1.32	4.87	5.15
T15	700	633	154	4.21	4.25	3.45	4.23	4.33	3.73	52	0.26	0.52	1.00	5.12	5.40

(3) Positional accuracy applies to in-line motor configurations only. Positional specifications are based on “no-load” conditions and apply to individual axes only.

(4) Consult factory for specs with linear feedback.

404XE Life-Load Performance

The following performance information is provided as a supplement to the product specifications pages. The useful life of a linear table at full catalog specifications is dependent on the forces acting upon it. These forces include both static components resulting from payload weight and dynamic components due to acceleration/ deceleration of the load. In multi-axes applications, the primary positioner at the bottom of the stack usually

establishes the load limits for the combined axes. When determining life/load, it is critical to include the weight of all positioning elements that contribute to the load supported by the primary axis. The following graphs and formulas are used to establish the table life relative to the applied loads.

Catalog load specifications are rated for 100 million inches of travel or 2.540 km.

Table Life/Thrust (Axial) Load

This graph illustrates table ballscrew life relative to the axial load.

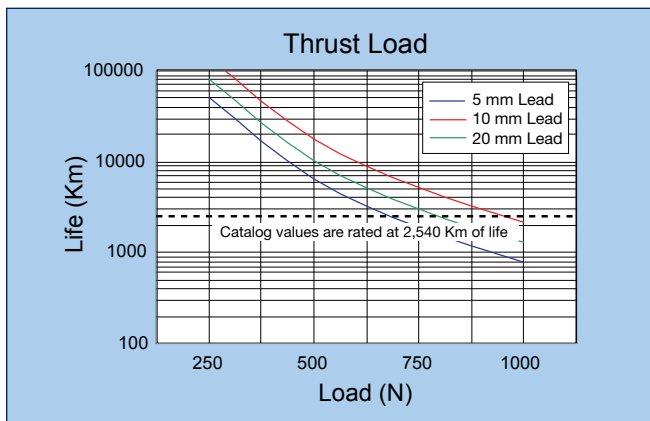

Table Life/Compression (Normal) Load

This graph provides an evaluation of the support bearing life/load characteristics. The curves show the life/load relationship when the applied load is centered on the carriage, normal (perpendicular) to the carriage mounting surface.

For final evaluation of life vs load, including off center, tension, and side loads refer to the pitch/moment chart for the NL carriage units or the bearing load charts (next page) for the VL carriage units.

**Table Life/Load Chart
Pitch Moment - NL (Short Carriage)**

This graph illustrates table linear bearing life as a result of pitch moment.

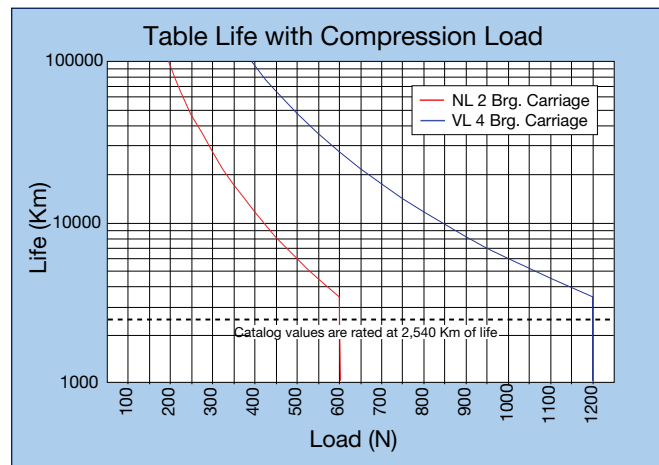
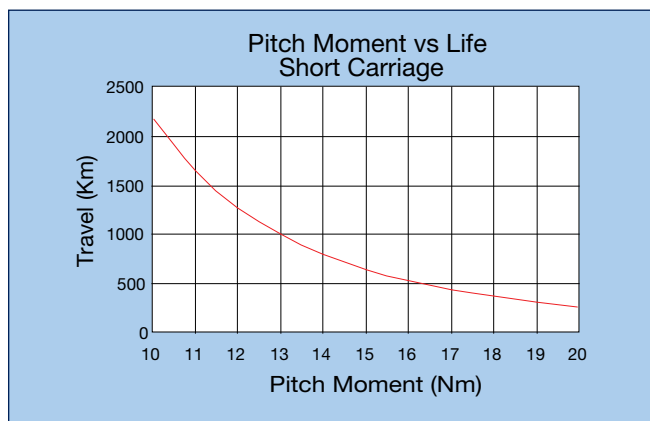



Bearing Life/Load for VL Long Carriage Units

These charts are to be used to evaluate the VL Carriage units. They should be used in conjunction with the corresponding formulas (found under “Product Information” at www.parkermotion.com) to establish the life/load for each bearing (4 per table).

Several dimensions, which are specific to each linear positioning table model, and the load geometry are required for these computations. These dimensions are supplied in the catalog information for each positioner. The dimensions are referenced as follows:

- d1 – bearing block center-to- center longitudinal spacing
- d2 – bearing rail center-to-center lateral spacing
- da – Rail center-to-carriage mounting surface

	d1	d2	da
404XE	80	57	28

Refer to Parker’s website www.parkermotion.com for moment loading and other engineering data.

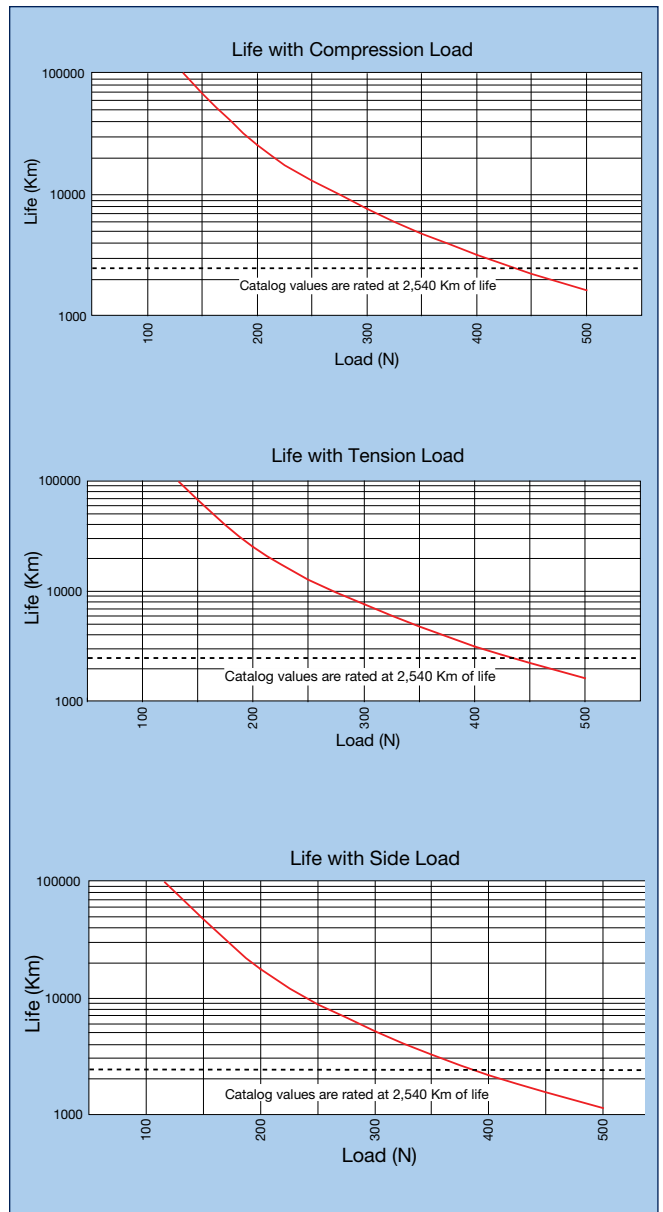

Screw Driven Tables

Home or Limit Sensor

End of Travel and Home Sensors for the 404XE series are available in a variety of styles. The sensors can be ordered as part of the table or as separate components with the associated mounting hardware or in an enclosed sensor pack. A 5 meter high-flex extension cable (Part No. 003-2918-01) is available for use with models having the locking connector option.



With Limits and Home Sensors

- NPN (Sinking) or PNP (Sourcing)
- Normally Closed (N.C.) or Normally Open (N.O.)
- Flying Leads or Locking Connector

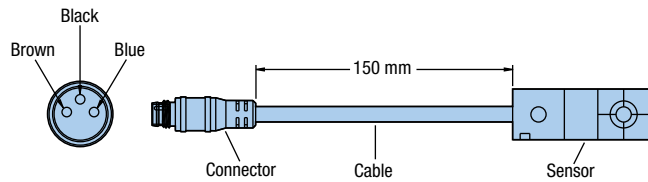

With Limits and Home Sensor Pack



Input Power 5-30 VDC, 20 mA
Output 100 mA max
Wire Color Code (+) Supply: Brown
 (-) Supply: Blue
 NO Output: Black
 NC Output: White

Order Code	Part No.* (Includes Mounting Bracket)	Switch Type	Logic	Cable Length	Connection Option
H2 or L2	006-1639-01	N.C.	Sinking	3.0 m	Flying Leads
H3 or L3	006-1639-02	N.O.	Sinking	3.0 m	Flying Leads
H4 or L4	006-1639-03	N.C.	Sourcing	3.0 m	Flying Leads
H5 or L5	006-1639-04	N.O.	Sourcing	3.0 m	Flying Leads
H6 or L6	006-1639-09	N.C.	Sinking	150 mm	Locking Connector
H7 or L7	006-1639-08	N.O.	Sinking	150 mm	Locking Connector
H8 or L8	006-1639-11	N.C.	Sourcing	150 mm	Locking Connector
H9 or L9	006-1639-10	N.O.	Sourcing	150 mm	Locking Connector

*Sensor triggers (targets) ordered separately.

Brake Assembly

Electromagnetic brake assembly used to prevent “backdriving” in vertical applications. Includes 5 m cable.

Table Series	Part Number	Input Power	Holding Torque
404XE	006-1627-01	24 VDC, 0.46 A	2.0 N-m

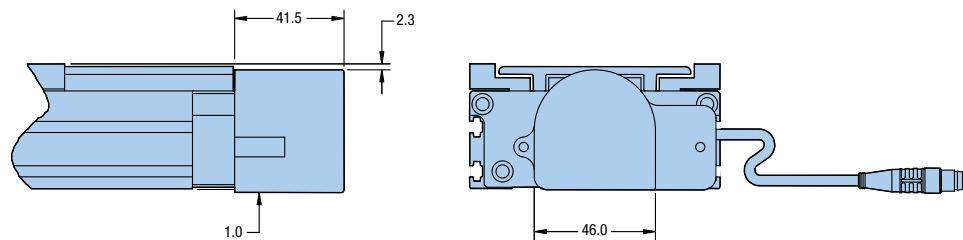



Rotary Encoder

Modular rotary encoder couples directly to the drive screw for position feedback. 150 mm cable included.

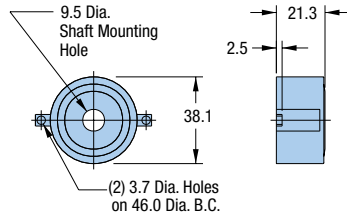

Part Number 06-1629-01

Input Power 5 VDC, 135 mA
Output A/B quadrature and reference mark, differential line drive output
Resolution 1250 lines/rev equals 5000 counts post quadrature (1 µm with 5 mm lead ballscrew)

Riser Plate

Used to raise the table base to provide clearance for motors larger than NEMA 23 frame size.

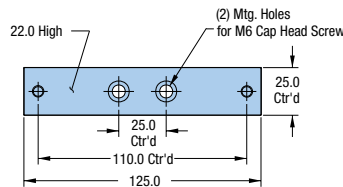

Part Number 002-3619-01
 (All hardware included)

Linear Feedback

A magnetic linear position feedback device which mounts directly to the table carriage. (Factory installation required.)



Input Power 5 VDC, 240 mA
Output A/B quadrature and reference marks, differential line drive output
Resolution 5.0 µmm

Dowel Pinning

Standard dowel pin locating holes are offered on all 400XE units to facilitate repeatable mounting of tooling or payload.

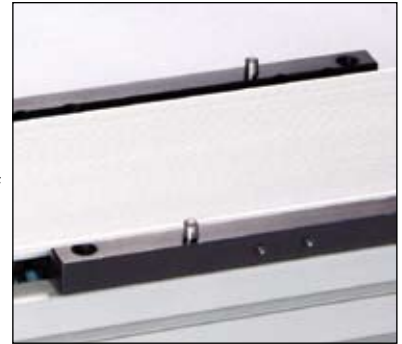

Two locating dowel pins shown in carriage

Multi-axis options are offered with P20 for the base 'X' Axis and P33-59 for the 'Y' orientation and mounting method. "Clock position" call-outs refer to the position of the motor end of the table. The multi-axis option allows the user to choose the motor orientation and mounting style.

P43 & P49 provide toe clamp mounting.

P33 & P39 offers standard pins on the carriage in addition to the toe clamps.

P53 & P59 offers uniquely pinned and toe clamp mounting to ensure the best orthogonality. This is offered for precise orthogonal mounting of the second axis in a multi-axis system. In this case, the bottom side of the table base is match drilled and reamed to the first axis to provide exact orthogonal location. This convenient option eliminates concerns regarding contamination or damage often associated with machining an assembled unit.



X-Y showing 12:00 and 9:00 positions

Toe Clamp

Used for convenient mounting of 404XE to a base plate, or riser plates.

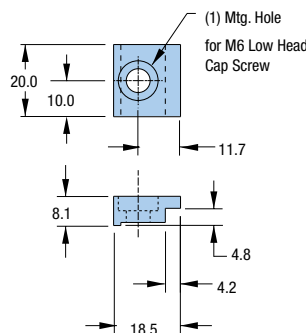

Part Number 002-3618-01

Screw Driven Tables

400XE Series Dimensions

Dimensions (mm)

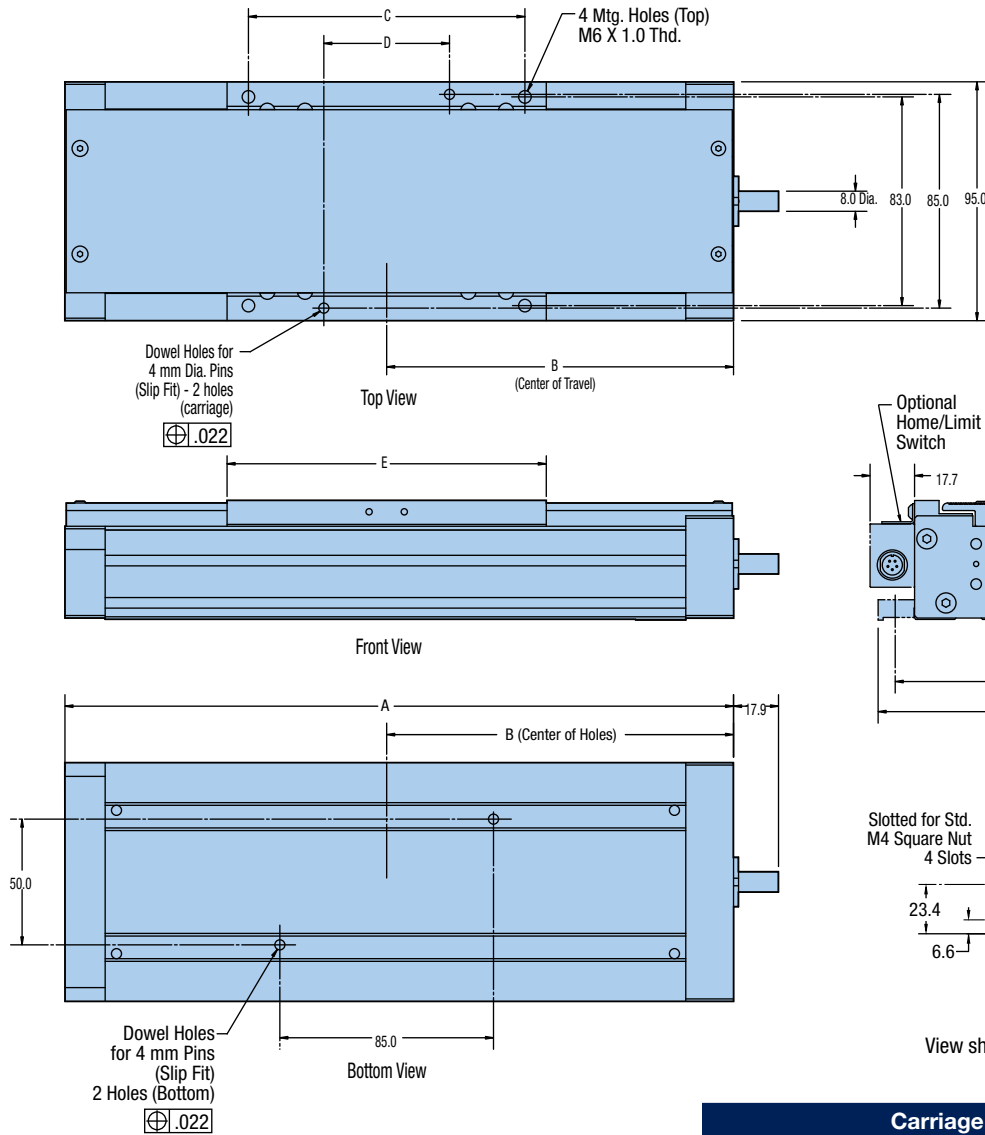

Carriage Type	C	D	E
NL	50.0	36.0	60.0
VL	110.0	50.0	127.0

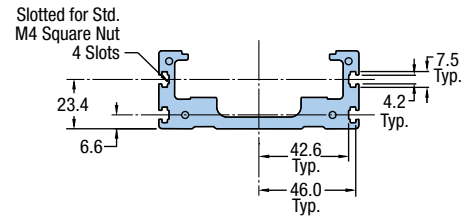
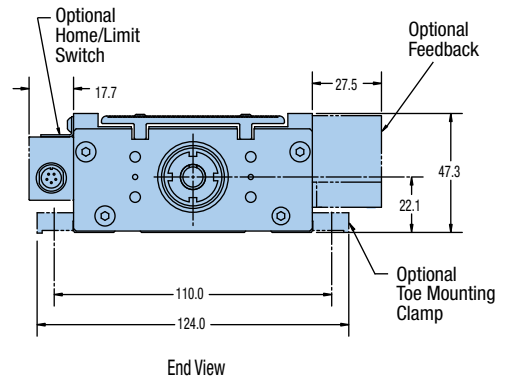

View showing slots in extruded base

Designation	Carriage Travel		A	B
	NL (short)	VL (long)		
T01	25	-	141.0	75.5
T02	50	-	166.0	88.0
T03	100	33	216.0	113.0
T04	150	83	266.0	138.0
T05	200	133	316.0	163.0
T06	250	183	366.0	188.0
T07	300	233	416.0	213.0
T08	350	283	466.0	238.0
T09	400	333	516.0	263.0
T10	450	383	566.0	288.0
T11	500	433	616.0	313.0
T12	550	483	666.0	338.0
T13	600	533	716.0	363.0
T15	700	633	816.0	413.0



400XE Series Motor Mount Dimensions

Dimensions (mm)

In-Line Motor Mount

In-line motor mounting allows the motor to be mounted directly to the drive screw via the selected motor coupling.

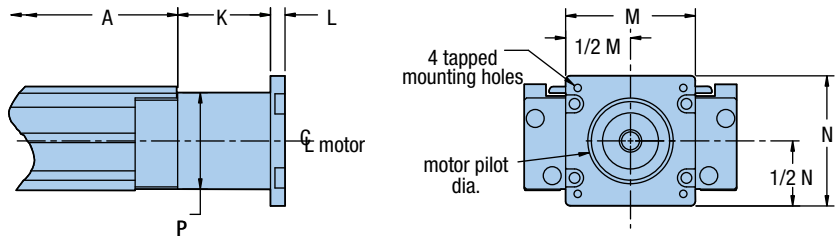

In-Line Adaptor Plates

Used to easily accommodate the mounting of different frame sizes. These adapter plates can be ordered separately by part number below.

Motor Size	Order Code	Max. Motor Shaft Dia.	K	L	M	N	P
SM16	M2	9.5	41.0	4.3	58.0	45.0	45.0
NEMA 23	M3	9.5	41.0	6.5	58.0	58.0	45.0
NEMA 34	M4	9.5	41.0	12.5	83.0	83.0	45.0
Neometric 70	M21	11.0	53.0	0.0	69.9	69.9	69.9

Screw Driven Tables

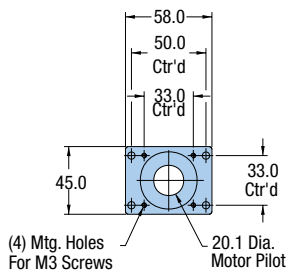

In-line SM 16

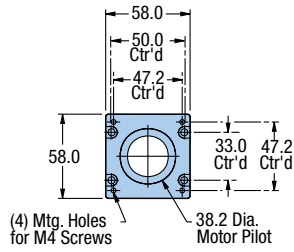

In-line NEMA 23

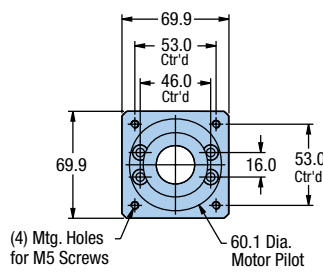

In-line NEOMETRIC 70 /SMN060

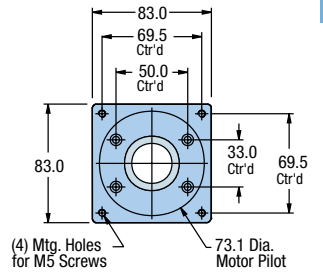

In-line NEMA 34

Parallel Motor Mounting

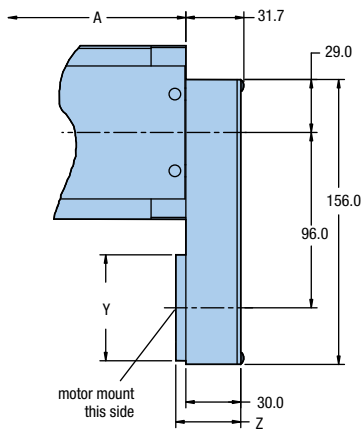

Parallel motor mounting is employed whenever a shorter overall unit length is needed. The motor is positioned along the sides or bottom of the table as designated by position A, B, or C. (No coupling required)

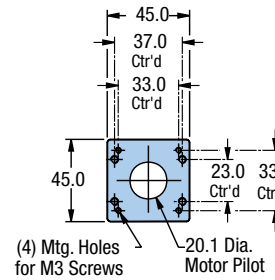

Reverse SM 16

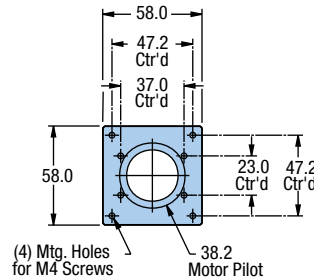

Reverse NEMA 23

Motor Size	Y	Z	Motor Shaft Dia.
SM 16	45.0	34.5	0.250"
SM 23 / BE 23	58.0	35.5	0.375"
NEMA 23	58.0	35.5	0.250"

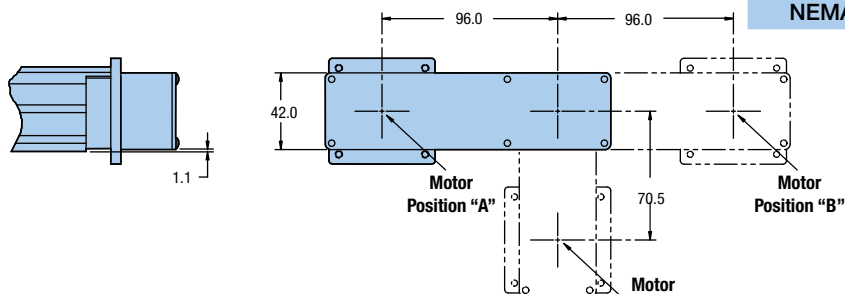

Note: Some sensor pack and encoder restriction apply when mounting motors larger than NEMA 23 in the A or B positions. Please consult factory.

Fill in an order code from each of the numbered fields to create a complete model order code.

① ② ③ ④ ⑤ ⑥ ⑦ ⑧ ⑨ ⑩ ⑪ ⑫ ⑬ ⑭ ⑮

Order Example: 404 T08 XE M S - VL D4 H8 L8 C3 M4 E1 B1 R11 P1

① **Series**
404

② **Table Travel (mm)**

	NL Short Carriage	VL Long Carriage
T01*	25	n/a
T02**	50	n/a
T03	100	33
T04	150	83
T05	200	133
T06	250	183
T07	300	233
T08	350	283
T09	400	333
T10	450	383
T11	500	433
T12	550	483
T13	600	533
T15	700	633

* VL carriage, D3 & D4 drives, and Limit/Home Sensor Pack option are not offered with T01 travel models.

** VL carriage, D4 drive options are not offered with T02 travel models.

③ **Table Style**

XE XE Series

④ **Mounting**

M Metric

⑤ **Grade**

S Standard Grade

⑥ **Carriage Style**

NL Short

VL Long

⑦ **Drive Screw**

D1 Free travel

D2 5 mm ballscrew

D3* 10 mm ballscrew

D4* 20 mm ballscrew

* D3 & D4 drives are not available with T01 travel. D4 drives are not available with T02 travels.

⑧ **Home Sensor (one sensor)**

- H1 No home sensor
- H2 N.C. current sinking, flying leads
- H3 N.O. current sinking flying leads
- H4 N.C. current sourcing, flying leads
- H5 N.O. current sourcing, flying leads
- H6 N.C. current sinking, with locking connector
- H7 N.O. current sinking, with locking connector
- H8 N.C. current sourcing, with locking connector
- H9 N.O. current sourcing, with locking connector
- H11 N.C. current sinking, sensor pack*
- H12 N.O. current sinking, sensor pack*
- H13 N.C. current sourcing, sensor pack*
- H14 N.O. current sourcing, sensor pack*

* Must be ordered with L11-L14 sensor option.

⑨ **Travel Limit Sensor Assembly (two sensors)**

- L1 No limit sensors
- L2 N.C. current sinking, flying leads
- L3 N.O. current sinking, flying leads
- L4 N.C. current sourcing, flying leads
- L5 N.O. current sourcing, flying leads
- L6 N.C. current sinking with locking connector*
- L7 N.O. current sinking with locking connector*
- L8 N.C. current sourcing with locking connector*
- L9 N.O. current sourcing with locking connector*
- L11 N.C. current sinking, sensor pack
- L12 N.O. current sinking, sensor pack
- L13 N.C. current sourcing, sensor pack
- L14 N.O. current sourcing, sensor pack

* Sensors with locking connector include 5 m extension cable.

**10 Motor Coupling**

C1	No coupling (required for parallel mounting)
C2	0.25" Oldham
C3	0.25" Bellows
C4	0.375" Oldham
C5	0.375" Bellows
C6	0.43" Oldham
C7	0.43" Bellows
C10	14 mm Oldham (M75 motor option)
C11	14 mm Bellows (M75 motor option)
C22	9 mm Oldham
C23	9 mm Bellows
C24	5 mm Oldham (M37 NEMA 17)
C25	5 mm Bellows (M37 NEMA 17)
C26	8 mm Oldham (M71 NEMA motor option)
C27	8 mm Bellows (M71 NEMA motor option)
C28	0.19" Oldham (M37 NEMA 17)
C29	0.19" Bellows (M37 NEMA 17)

11 Motor Mount*

M1	No motor mount
M2	SM 16 In-line mounting
M3	NEMA 23 & SM 23 – In-line mounting
M4	NEMA 34 – In-line mounting
M5	SM16 – Parallel mounting, "A" location
M6	SM16 – Parallel mounting, "B" location
M7	SM16 – Parallel mounting, "C" location
M8	NEMA 23 – Parallel mounting, "A" location
M9	NEMA 23 – Parallel mounting, "B" location
M10	NEMA 23 – Parallel mounting, "C" location
M11	SM23 – Parallel mounting, "A" location
M12	SM23 – Parallel mounting, "B" location
M13	SM23 – Parallel mounting, "C" location
M21	Neometric 70 – In-line mounting
M37	NEMA 17 – In-line mounting
M42	SM232AQ-NPSN Servo motor – In-line mounting
M46	HV232-02-10 Stepper motor – In-line mounting
M49	Handcrank/no read out
M51	HDY55 – In-line mounting
M61	BE23 – In-line mounting
M62	BE23 – Parallel mounting, "A" location
M63	BE23 – Parallel mounting, "B" location
M64	BE23 – Parallel mounting, "C" location
M71	SGM01 – In-line mounting
M72	SGM01 – Parallel mounting, "A" location
M73	SGM01 – Parallel mounting, "B" location
M74	SGM01 – Parallel mounting, "C" location
M75	SGM02 – In-line mounting

* Refer to "Motor Mounting Dimensions" for maximum allowable motor shaft diameter.

12 Feedback Option

E1	None
E2	Linear feedback – 5 micron magnetic (not available on T01 units with H2-H9 "home" and L2-L9 "limit" sensors)
E5	Rotary shaft encoder (cannot be used with brake option)

13 Brake Option

B1	No brake
B2	Shaft brake (cannot be used with rotary encoder option)

14 Environmental Protection

R11	Hard cover
R12	Hard cover, cleanroom prep
R13	No cover
R14	No cover, cleanroom prep

15 Multi-Axis Selections

P1	X axis – for single axis use
P20	X axis – for X-Y assembly (VL carriage units only) – motor @ 12:00
P33	Y axis, standard dowel pinned & toe clamped to X axis – motor @ 3:00
P39	Y axis, standard dowel pinned & toe clamped to X axis – motor @ 9:00
P43	Y axis, toe clamped to X axis motor @ 3:00
P49	Y axis, toe clamped to X axis motor @ 9:00
P53	Y axis, precision dowel pinned & toe clamped to X axis motor @ 3:00
P59	Y axis, precision dowel pinned & toe clamped to X axis motor @ 9:00