

Linear units with spindle drive

LES 5



LES 5 with integrated belt drive module

Features

- Aluminium shaft housing profile W225 × H75 mm, naturally anodised
- Clamping area and profile underside milled flat
- With 4 precision steel shafts Ø 12 h6, material Cf53, Hardness 60 ± 2 HRC
- Aluminium shaft slides WS 5/70, 2 x WS 5/70 (70 mm long), adjustable for no play, central lubrication system
- Recirculating ball drive 2.5/4/5/10 and 20 mm pitches
- Profile sealing with friction-resistant lip seals
- Cast aluminium end plates
- With 2 limit or reference switches, Repeat accuracy ± 0.02 mm
- Sealed angular contact bearings in drive - steel flange

Ordering key

2 3 4 X X X 0 X X X

Drive

- 3 = Preparation Direct drive modules
- 4 = Preparation Belt drive module

Shaft slides

- 0 = 2 Shaft slides 70 mm
- 1 = 2 Shaft slides 200 mm
- 2 = 4 Shaft slides 70 mm

Profile length (L1)

- e.g. 029 = 290 mm (min.)
- 299 = 2990 mm (max.)

(rounded to the last digit)

Standard profile lengths available in 100 mm raster

Recirculating ball drive

- 0 = without
- 1 = Pitch 2.5 mm
- 2 = Pitch 4.0 mm
- 3 = Pitch 5.0 mm
- 4 = Pitch 10 mm
- 5 = Pitch 20 mm

Options:

- Black anodized aluminium profile
- Electromagnetic brake
- Steel slides LS2 (Part no. 223007)
- Limit switch attachment kit (see accessories)

Available on request:

- Length measuring system
- Bellows gaiter cover

Drive modules

see pages 2-66 et seq. of the catalogue



Technical specification

Aluminium profile

Aluminium profile LES 5	
Moment of inertia I _x	2,361.654 cm ⁴
Moment of inertia I _y	298.925 cm ⁴
*Centre of gravity <small>see dimensioned drawing</small>	33.39 mm
Cross-sectional area	42.49 cm ²
Material	AlMgSi0, 5F22
Anodising	E6/EV1
Weight with steel shafts	13.8 kg/m
Weight with steel shafts and spindles	15.2 kg/m

No load running torques

No load torques (Ncm)					
Speed (rpm)	Spindle pitch				
	2.5	4	5	10	20
500	15	15	16	17	18
1500	19	19	19	20	21
3000	23	24	24	25	26

Linear units with spindle drive

LES 5

Bending

■ Load config. 1

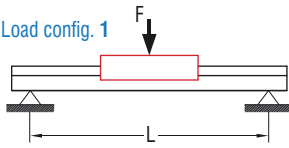

■ Load config. 2

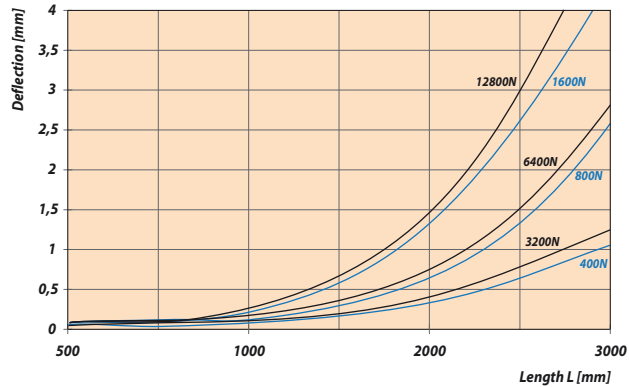
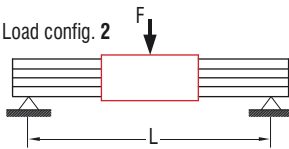

Load factors

$$F_r(\alpha) = \frac{F_2}{\cos \alpha}$$

$$F_r(\alpha) = \frac{F_1}{\sin \alpha}$$

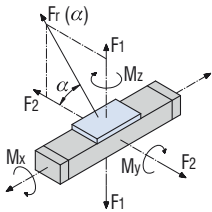

LES 5 with two WS 5/70		LES 5 with four WS 5/70	
C_0	5,153.30 N	C_0	6,606 N
C	2,319.41 N	C	3,746 N
F_1 stat.	4,401.33 N	F_1 stat.	5,642 N
F_1 dyn.	1,980.96 N	F_1 dyn.	3,198 N
F_2 stat.	5,153.30 N	F_2 stat.	6,606 N
F_2 dyn.	2,319.14 N	F_2 dyn.	3,746 N
M_x stat.	376.59 Nm	M_x stat.	423.15 Nm
M_y stat.	164.31 Nm	M_y stat.	366.73 Nm
M_z stat.	192.39 Nm	M_z stat.	429.39 Nm
M_x dyn.	169.49 Nm	M_x dyn.	239.85 Nm
M_y dyn.	73.95 Nm	M_y dyn.	207.87 Nm
M_z dyn.	86.59 Nm	M_z dyn.	243.49 Nm

Permissible spindle speeds

LES 4 / 5 / 6	Spindle pitch p [mm]	max. permissible feed speed v permissible [mm/s]				
		2.5	4	5	10	20
490	4000	167	267	333	667	1333
990	3000	125	200	250	500	1000
1390	1500	63	100	125	250	500
1490 *	3000	125	200	250	500	500
1990 *	1650	69	110	138	275	550
2490 *	1050	44	70	88	175	350
2990 *	750	31	50	63	125	250

* with spindle support

Dimensioned drawing

Process travel
 at 2xWS 5/70 = L1 -150 mm
 at 4xWS 5/70 = L1 -280 mm

external limit switches see pages 2-81

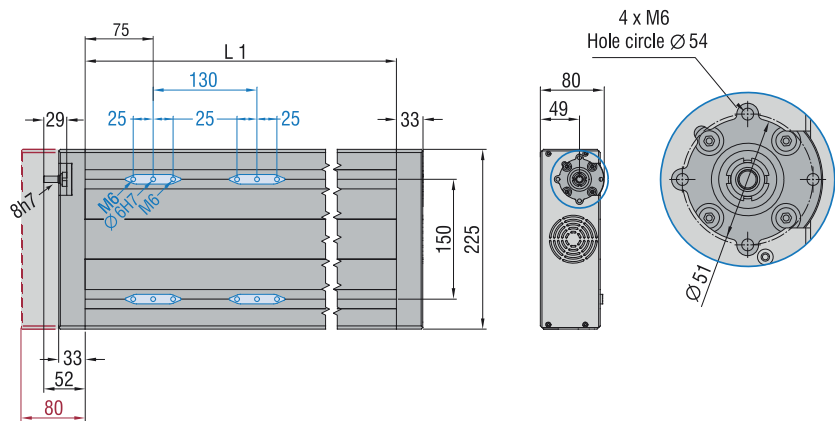

Dimensioned drawing

Aluminium profile

