

Linear units with spindle drive

LES 4



LES 4 with side-mounted belt drive module

Features

- Aluminium shaft housing profile W75 × H75 mm, naturally anodised
- Clamping area and profile underside milled flat
- with 2 precision steel shafts Ø 12 h6, material Cf53, Hardness 60 ± 2 HRC
- Aluminium shaft slides WS 5/70, 2 x WS 5/70 (70 mm long), adjustable for no play, central lubrication system
- Recirculating ball drive 2.5/4/5/10 and 20 mm pitches
- Profile sealing with friction-resistant lip seals
- Cast aluminium end plates
- With 2 limit or reference switches, Repeat accuracy ± 0.02 mm
- Sealed angular contact bearings in drive - steel flange

Ordering key

2 3 4 X X X 0 X X X

Drive

- 0 = Preparation Direct drive modules
- 1 = Preparation Belt drive module

Shaft slides

- 0 = 1 Shaft slides 70 mm
- 1 = 1 Shaft slides 200 mm
- 2 = 2 Shaft slides 70 mm

Profile length (L1)

- e.g. 029 = 290 mm (min.)
- 299 = 2990 mm (max.)

(rounded to the last digit)

Standard profile lengths available in 100 mm raster

Recirculating ball drive

- 0 = without
- 1 = Pitch 2.5 mm
- 2 = Pitch 4.0 mm
- 3 = Pitch 5.0 mm
- 4 = Pitch 10 mm
- 5 = Pitch 20 mm

Options:

- Black anodized aluminium profile
- Electromagnetic brakes in the motor module or in drive spindle extension
- Steel slide LS2 (Part no. 223007)
- External limit switch attachment set (see accessories)

Available on request:

- Length measuring system
- Bellows gaiter cover
- Assembly left of the motor module

Drive modules

see pages 2-66 et seq. of the catalogue

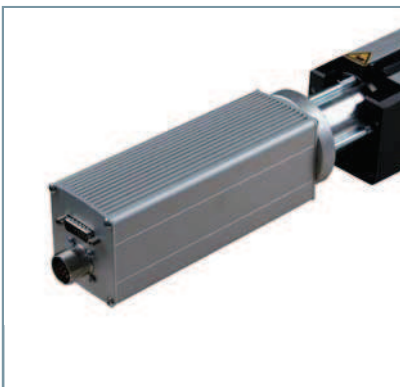

Technical specification

Aluminium profile

Aluminium profile LES 4	
Moment of inertia I _x	107.711 cm ⁴
Moment of inertia I _y	125.843 cm ⁴
*Centre of gravity <small>see dimensioned drawing</small>	33.23 mm
Cross-sectional area	18.81 cm ²
Material	AlMgSi0, 5F22
Anodising	E6/EV1
Weight with steel shafts	6.2 kg/m
Weight with steel shafts and spindles	7.6 kg/m

No load running torques

No load torques (Ncm)					
Speed (rpm)	Spindle pitch				
	2.5	4	5	10	20
500	15	15	16	17	18
1500	19	19	19	20	21
3000	23	24	24	25	26

Linear units with spindle drive

LES 4

Bending

Load config. 1

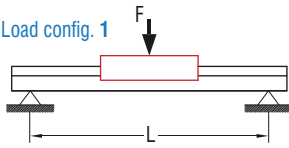

Load config. 2

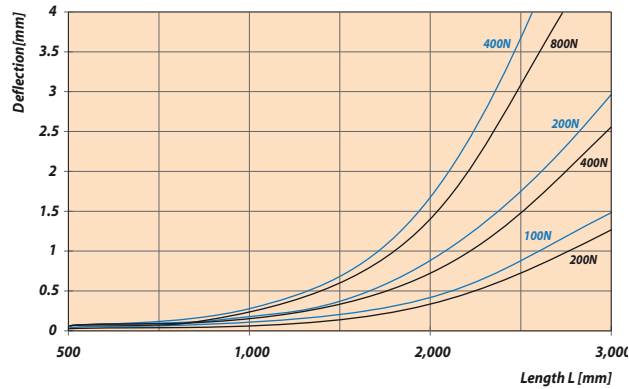
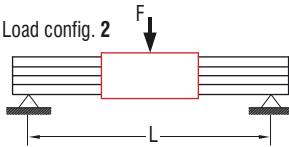

Load factors

$$F_r(\alpha) = \frac{F_2}{\cos \alpha}$$

$$F_r(\alpha) = \frac{F_1}{\sin \alpha}$$

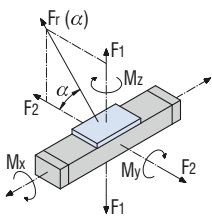

LES 4 with one WS 5/70	
C_0	2,576.65 N
C	1,461.14 N
F_1 stat.	2,200.67 N
F_1 dyn.	1,247.93 N
F_2 stat.	2,576.65 N
F_2 dyn.	1,461.14 N
M_x stat.	36.45 Nm
M_y stat.	82.16 Nm
M_z stat.	96.20 Nm
M_x dyn.	20.67 Nm
M_y dyn.	46.59 Nm
M_z dyn.	54.55 Nm

LES 4 with two WS 5/70	
C_0	4,954.5 N
C	2,809.5 N
F_1 stat.	4,231.5 N
F_1 dyn.	2,398.5 N
F_2 stat.	4,954.5 N
F_2 dyn.	2,809.5 N
M_x stat.	44.7 Nm
M_y stat.	126.945 Nm
M_z stat.	148.635 Nm
M_x dyn.	25.2 Nm
M_y dyn.	71.955 Nm
M_z dyn.	84.285 Nm

permissible spindle speeds

LES 4 / 5 / 6	Spindle pitch p [mm]	2.5	4	5	10	20
		max. permissible spindle speed n [rpm]		max. permissible feed speed v permissible [mm/s]		
490	4000	167	267	333	667	1333
990	3000	125	200	250	500	1000
1390	1500	63	100	125	250	500
1490 *	3000	125	200	250	500	1000
1990 *	1650	69	110	138	275	550
2490 *	1050	44	70	88	175	350
2990 *	750	31	50	63	125	250

* with spindle support

dimensioned drawing

process travel

at 1 x WS 5/70 = L1 -150 mm
at 2 x WS 5/70 = L1 -280 mm

external limit switches see pages 2-83

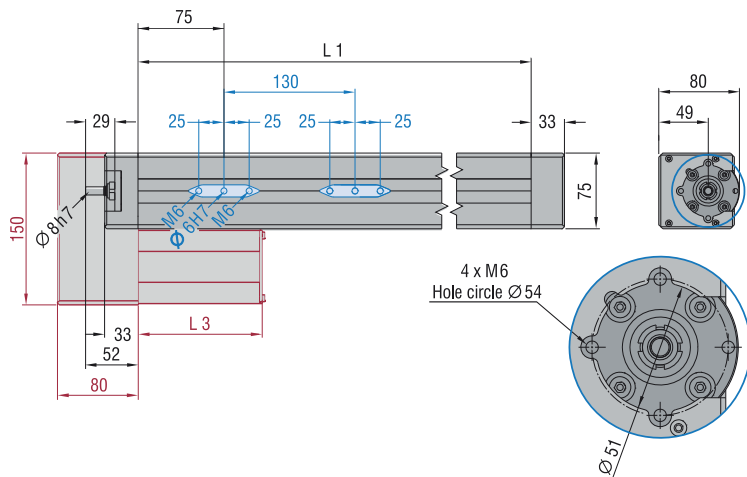

dimensioned drawing

Aluminium profile

